

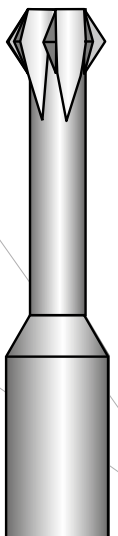

SEF DEBURRING  
**TECNOLOGIA DI  
 SBAVATURA A  
 MANO E A  
 MACCHINA**



Applicazioni ad alto rendimento



## La precisione dal 1948.

Dalla ricostruzione del dopoguerra all'applicazione diffusa dei sistemi informatici: un'ascesa tecnologica che ha profondamente modificato i costumi e i metodi della produzione industriale nel nostro paese.

Oltre sessant'anni, due generazioni si sono succedute alla guida della Sef, ma la matrice che ha segnato lo sviluppo costante della nostra società è sempre la medesima: il piacere di cavalcare un'evoluzione straordinaria, alla ricerca incessante di nuove tecnologie per l'immediato futuro.

Con una passione che ci ha consentito di svolgere un lavoro davvero importante: non tanto in termini di volume,

ma certamente per la qualità dei servizi offerti e per lo sforzo necessario a mantenere un livello di specializzazione sempre al passo con i tempi.

Al di là del gratificante successo aziendale, la nostra più grande soddisfazione si traduce nell'aumento qualitativo del prodotto dei clienti e nella maggiore competitività della loro produzione.

Tanta dedizione ed operosità si confrontano oggi con un nuovo impegno: quello di trasferire ai più giovani un prezioso patrimonio fatto di scuola tecnica e partecipazione umana, fianco a fianco con il cliente per la soluzione ottimale delle più diverse problematiche inerenti ai processi produttivi.

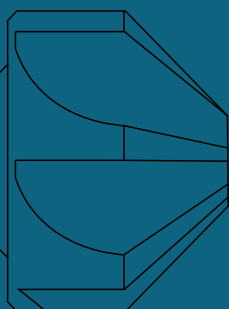

# Frese in spinta ed in tiro in MDI

---



---

**FW 99**  
Norme interne

**Frese in MD integrale**

---

# Sbavatori a Forcella in MDI

---



---

**4100**  
Norme interne

**Sbavatore a Forcella  
per pinze**

---



---

**4101**  
Norme interne

**Sbavatore a Forcella  
per mandrini idraulici ed a calettamento**

---

**FW 99**  
**Norme interne**

**Frese MD**  
**per smussi in tiro e spinta**

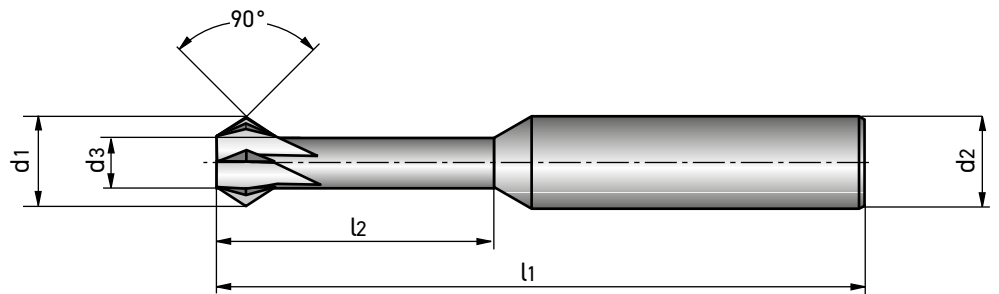

**Geometria:**  
 metallo duro integrale con gambo rinforzato secondo  
 DIN 6535 forma HA,  
**Grado:** Metallo duro micrograna

**Applicazioni:**  
 Smussatura di acciaio fuso, acciaio da costruzioni, acciaio da  
 utensili, acciai al nickel, acciai refrattari. **Il rivestimento AF**  
**è particolarmente indicato per la lavorazione a secco.**

**Rivestimento:** AF   $\hat{=}$  TiAlN

Codice Nr.	d1 h10 mm	d2 -2/h6 mm	d3 mm	l1 mm	l2 mm	z	Codice Nr.	d1 h10 mm	d2 -2/h6 mm	d3 mm	l1 mm	l2 mm	z
399 0300	3,0	6	2,0	70	17	5	399 0760	7,6	8	4,7	70	20	7
399 0450	4,5	6	2,5	70	15	7	399 0970	9,7	10	5,5	70	30	8
399 0550	5,5	6	3,2	70	15	7	399 0115	11,5	12	7,5	70	30	9
399 0650	6,5	8	4,0	70	20	7							

Smussatura in tiro

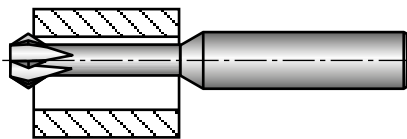

Smussatura in spinta

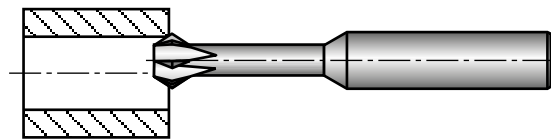

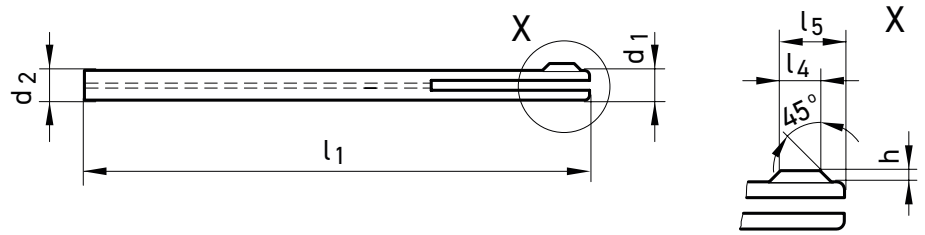

4100

Norme  
interne

## Sbavatore a Forcella in MDI per pinze

### Geometria:

con refrigerazione interna. Con codolo cilindrico passante per impiego con pinze di serraggio Per sbavatura interna ed esterna, di impiego universale su macchine utensili, fresatrici, torni e robots.

### Applicazioni:

Smussatura di acciai, inox, ghisa, superleghe.  
Possibile utilizzo su materiali duri e materiali non ferrosi.

Per $\varnothing$ inclusi tra	$d_1$ (mm)	$d_2$ (mm)	$l_1$ (mm)	$l_4$ (mm)	$l_5$ (mm)	h (mm)
1,91-2,15	1,9	1,9	80	1,0	2,05	0,35
2,16-2,40	2,1	2,1	80	1,5	2,60	0,40
2,41-2,70	2,4	2,4	80	1,5	2,90	0,40
2,71 -2,90	2,6	2,6	90	1,5	2,95	0,45
2,91-3,25	2,9	2,9	90	2,0	3,65	0,45
3,26-3,60	3,2	3,2	90	2,0	3,80	0,60
3,61-4,25	3,6	3,6	90	2,0	4,10	0,70
4,26-4,75	4,2	4,2	90	2,5	4,60	0,70
4,76-5,30	4,7	4,7	100	2,5	4,85	0,75
5,31-5,80	5,2	5,2	100	2,5	4,85	0,75
5,81-6,20	5,6	5,6	110	3,0	5,80	0,80
6,21-6,70	6,0	6,0	110	3,0	5,90	0,90
6,71-7,10	6,5	6,5	110	3,0	5,85	0,85
7,11-7,60	6,9	6,9	110	3,5	6,95	0,95
7,61-8,05	7,3	7,3	110	3,5	7,00	1,00

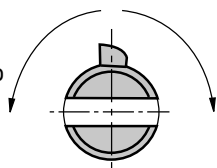
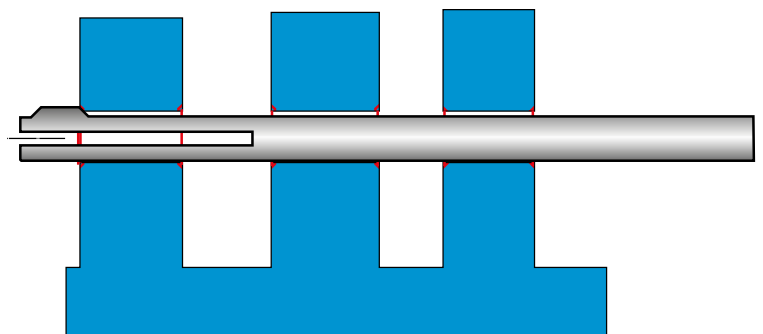
Rotazione  
destra di lavoroRotazione  
sinistra di  
avanzamento

4101

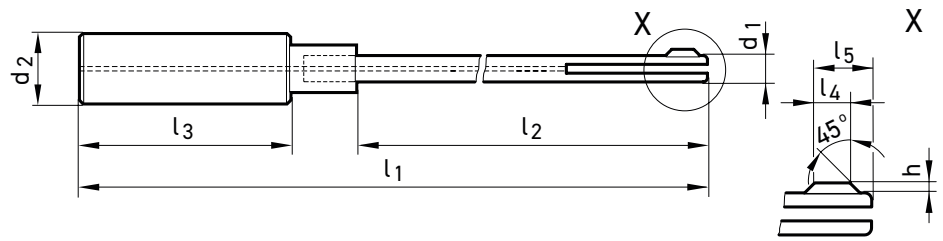
Norme  
interne

## Sbavatore a Forcella in MDI per mandrini idraulici ed a calettamento

### Geometria:

con refrigerazione interna. Con codolo DIN 6535 passante per per impiego in mandrini a espansione idraulica e per calettamento per sbavatura interna ed esterna, di impiego universale su macchine utensili, fresatrici, torni e robots.

### Applicazioni:

Smussatura di acciai, inox, ghisa, superleghe.  
Possibile utilizzo su materiali duri e materiali non ferrosi.

Per $\varnothing$ inclusi tra	$d_1$ (mm)	$d_2$ (mm)	$l_1$ (mm)	$l_2$ (mm)	$l_3$ (mm)	$l_4$ (mm)	$l_5$ (mm)	h (mm)
1,91-2,15	1,9	6	120	69	36	1,0	2,05	0,35
2,16-2,40	2,1	6	120	69	36	1,5	2,60	0,40
2,41-2,70	2,4	6	120	69	36	1,5	2,90	0,40
2,71 -2,90	2,6	6	130	79	36	1,5	2,95	0,45
2,91-3,25	2,9	6	130	79	36	2,0	3,65	0,45
3,26-3,60	3,2	10	135	80	40	2,0	3,80	0,60
3,61-4,25	3,6	10	135	80	40	2,0	4,10	0,70
4,26-4,75	4,2	10	135	80	40	2,5	4,60	0,70
4,76-5,30	4,7	10	145	80	40	2,5	4,85	0,75
5,31-5,80	5,2	10	145	90	40	2,5	4,85	0,75
5,81-6,20	5,6	10	155	90	40	3,0	5,80	0,80
6,21-6,70	6,0	16	165	102	48	3,0	5,90	0,90
6,71-7,10	6,5	16	165	102	48	3,0	5,85	0,85
7,11-7,60	6,9	16	165	102	48	3,5	6,95	0,95
7,61-8,05	7,3	16	165	102	48	3,5	7,00	1,00

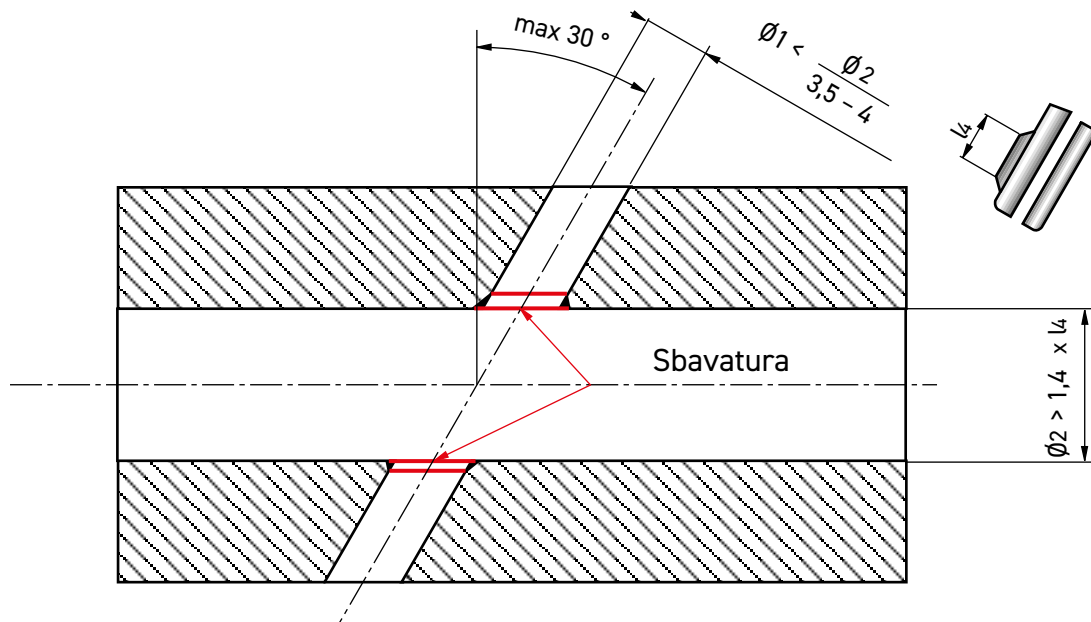

# Svasatori elicoidali in MDI

---



---

**5001**

**Svasatori elicoidali 60°**

Norme interne

---



---

**5002**

**Svasatori elicoidali 90°**

Norme interne

---



---

**5003**

**Svasatori elicoidali 120°**

Norme interne

---

5001

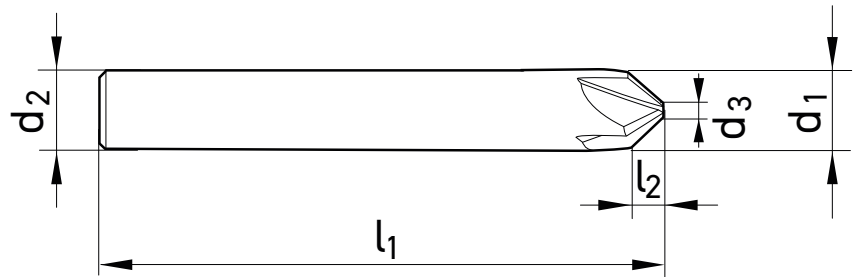
Norme  
interne**Svasatore elicoidale 60°**

rivestito, con taglio frontale, senza taglio al centro

d1 js9 (mm)	d2 h6 (mm)	d3 (mm)	l1 (mm)	l2 (mm)	Z
6	6	1,5	57	3,9	5
8	8	2	63	5,2	5
10	10	2,5	72	6,5	5
12	12	3	83	7,8	5
16	16	4	92	10,4	5
20	20	5	104	13	5

5002

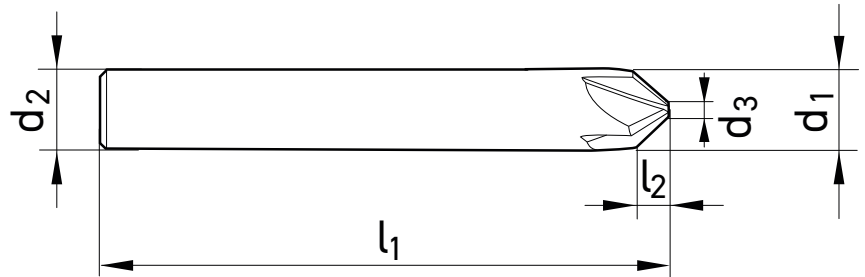
Norme  
interne**Svasatore elicoidale 90°**

rivestito, senza taglio al centro

d1 js9 (mm)	d2 h6 (mm)	d3 (mm)	l1 (mm)	l2 (mm)	Z
6	6	1,5	57	2,25	5
8	8	2	63	3	5
10	10	2,5	72	3,75	5
12	12	3	83	4,5	5
16	16	4	92	6	5
20	20	5	104	7,5	5

5003

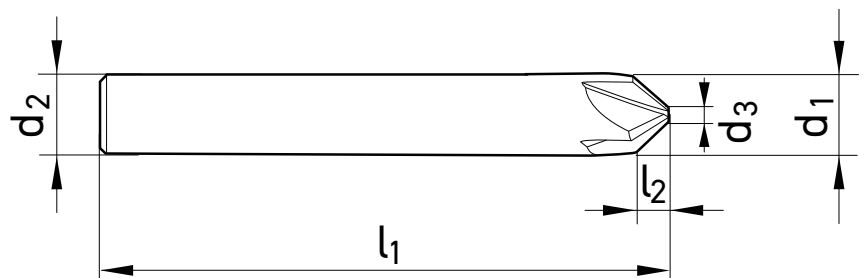
Norme  
interne**Svasatore elicoidale 120°**

rivestito, senza taglio al centro

d1 js9 (mm)	d2 h6 (mm)	d3 (mm)	l1 (mm)	l2 (mm)	Z
6	6		57	1,3	5
8	8		63	1,73	5
10	10		72	2,17	5
12	12		83	2,6	5
16	16		92	3,46	5
20	20		104	4,33	5

# TuffCut® Series 5HC

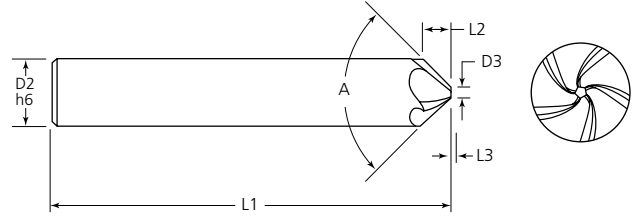
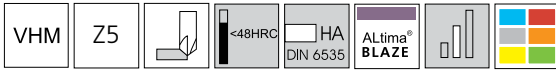

**NEW**  
Products

Nouveaux produits  
Neue Produkte  
Nuovi Prodotti  
Nowe Produkty

Tool Number	EDP	D2	D3	Angle	L1	L2	L3
5HCM06003B	35026	6.0	1.5	90°	57.0	2.25	0.75
5HCM08003B	35027	8.0	1.75	90°	63.0	3.125	0.875
5HCM10003B	35028	10.0	1.75	90°	72.0	4.125	0.875
5HCM12003B	35029	12.0	2.0	90°	83.0	5.0	1.0
5HCM16003B	35030	16.0	2.25	90°	92.0	6.875	1.125

## TuffCut® Series 5HC

Recommended cutting data | Conditions de coupe recommandées | Empfohlene Schnittdaten | Dati di taglio Raccomandati | Zalecane Parametry

**NEW**  
Products

Nouveaux produits  
Neue Produkte  
Nuovi Prodotti  
Nowe Produkty

Workpiece Material Group	Material Type	Coolant			Vc-m/min	Tool Diameter					
		Max	Air	MMS		6mm	8mm	10mm	12mm	16mm	
						fz-mm/tooth					
Steels	P	Low Carbon Steels	●	●	●	350	0.072	0.096	0.120	0.144	0.192
		Medium Carbon Steels	●	●	●	270	0.048	0.064	0.080	0.096	0.128
		Alloy Tool Steels	●	●	●	250	0.048	0.064	0.080	0.096	0.128
		Die/Tool Steels	●	●	●	220	0.042	0.056	0.070	0.084	0.112
Stainless Steels	M	Free Machining Stainless	●	X	○	180	0.042	0.056	0.070	0.084	0.112
		Austenitic Stainless	●	X	○	130	0.036	0.048	0.060	0.072	0.096
		Difficult Stainless	●	X	○	75	0.030	0.040	0.050	0.060	0.080
		PH Stainless	●	X	○	130	0.036	0.048	0.060	0.072	0.096
		Cobalt Chrome Alloys	●	X	○	75	0.030	0.040	0.050	0.060	0.080
		Duplex (22%)	●	X	○	75	0.030	0.040	0.050	0.060	0.080
		Super Duplex (25%)	●	X	○	55	0.030	0.040	0.050	0.060	0.080
Special Alloys	S	High Temp Alloys	●	X	X	45	0.030	0.040	0.050	0.060	0.080
		Titanium Alloys	●	X	X	100	0.036	0.048	0.060	0.072	0.096
Cast Irons	K	Grey Cast Iron	●	○	○	300	0.084	0.112	0.140	0.168	0.224
		Ductile Cast Iron	●	○	○	190	0.060	0.080	0.100	0.120	0.160
Hardened Steels	H	Hardened Steels 45 - 50HRC	○	●	○	80	0.030	0.040	0.050	0.060	0.080
		Hardened Steels 50 - 55HRC	○	●	○	60	0.036	0.048	0.060	0.072	0.096
Non Ferrous	N	Aluminium Alloys	●	X	○	600	0.072	0.096	0.120	0.144	0.192
		Brass / Bronze / Copper	●	X	○	350	0.054	0.072	0.090	0.108	0.144

● Preferred ○ Possible X Not Possible

### Please note:

Technical data provided should be considered as advisory only and alterations may be necessary depending on the specific application.

Decreased feeds and/or a finish pass may be required to reach the desired surface finish requirements.

Decreased speeds and feeds may be required for heavy duty cutting.

Cutting speed (Vc) should be calculated from the effective cutting diameter using the following formula:

(Major diameter D2 + minor diameter D3) / 2.

Alternatively, estimate the actual diameter that is in contact with the workpiece.

# TuffCut® GP Series FBCM

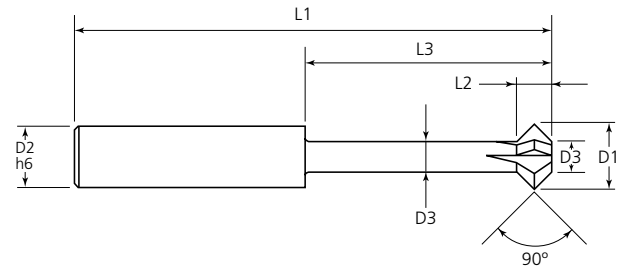
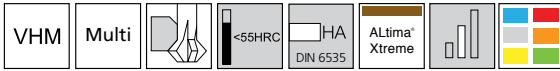

**NEW Products**

Nouveaux produits  
Neue Produkte  
Nuovi Prodotti  
Nowe Produkty

Tool Number	D1	D2	D3	L1	L2	L3	Z	Max CHF
FBCM 03N3H	3.0	4.0	1.5	50.0	1.5	11.5	3	0.6
FBCM 04N3H	4.0	4.0	2.0	50.0	2.0	15.0	3	0.9
FBCM 05N3H	5.0	6.0	2.5	57.0	2.5	18.5	3	1.1
FBCM 06N3H	6.0	6.0	3.0	64.0	3.0	22.0	3	1.4
FBCM 08N3H	8.0	8.0	4.0	63.0	4.0	29.0	4	1.8
FBCM 10N3H	10.0	10.0	5.0	72.0	5.0	36.0	5	2.3
FBCM 12N3H	12.0	12.0	6.0	83.0	6.0	43.0	5	2.8

Front chamfer

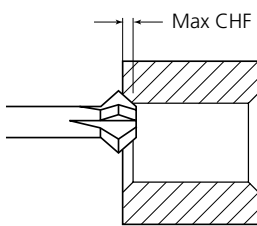

Back chamfer

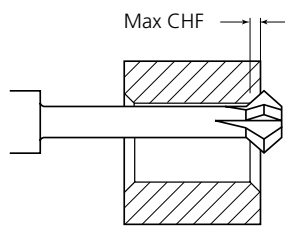

## TuffCut® GP Series FBCM

Recommended cutting data | Conditions de coupe recommandées | Empfohlene Schnittdaten | Dati di taglio Raccomandati | Zalecane Parametry

### Recommended Speeds by Material Group

Workpiece Material Group	Material Type	Coolant			Deburr	Chamfer	
		Max	Air	MMS	Vc-m/min		
Steels	P	Low Carbon Steels	●	●	●	230	220
		Medium Carbon Steels	●	●	●	200	185
		Alloy Tool Steels	●	●	●	175	165
		Die/Tool Steels	●	●	●	145	130
Stainless Steels	M	Free Machining Stainless	●	X	○	120	110
		Austenitic Stainless	●	X	○	110	100
		Difficult Stainless	●	X	○	75	65
		PH Stainless	●	X	○	110	100
		Cobalt Chrome Alloys	●	X	○	75	65
		Duplex (22%)	●	X	○	75	65
		Super Duplex (25%)	●	X	○	55	45
Special Alloys	S	High Temp Alloys	●	X	X	35	28
		Titanium Alloys	●	X	X	75	66
Cast Irons	K	Grey Cast Iron	●	○	○	200	175
		Ductile Cast Iron	●	○	○	185	165
Hardened Steels	H	Hardened Steels 45 - 50HRC	○	●	○	60	50
		Hardened Steels 50 - 55HRC	○	●	○	50	45
Non Ferrous	N	Aluminium Alloys	●	X	○	300	250
		Brass / Bronze / Copper	●	X	○	180	170

Please note:

Use the following formula to calculate the effective cutting diameter:  
 (Major diameter D1 + minor diameter D3) / 2.

Alternatively, estimate the actual diameter that is in contact with the workpiece.

● Preferred ○ Possible X Not Possible

### Recommended Feed per Tooth by Material Group

Workpiece Material Group	Type of Machining	Tool Diameter							
		3mm	4mm	5mm	6mm	8mm	10mm	12mm	
		fz-mm/tooth							
Steels	P	Deburr	0.015	0.020	0.025	0.030	0.040	0.050	0.060
		Chamfer	0.008	0.010	0.013	0.015	0.020	0.025	0.030
Stainless Steels	M	Deburr	0.015	0.020	0.025	0.030	0.040	0.050	0.060
		Chamfer	0.008	0.010	0.013	0.015	0.020	0.025	0.030
High Temp Alloys	S	Deburr	0.004	0.006	0.007	0.016	0.019	0.022	0.026
		Chamfer	0.002	0.003	0.004	0.008	0.010	0.011	0.013
Titanium	S	Deburr	0.015	0.020	0.025	0.030	0.040	0.050	0.060
		Chamfer	0.008	0.010	0.013	0.015	0.020	0.025	0.030
Cast Irons	K	Deburr	0.015	0.020	0.025	0.030	0.040	0.050	0.060
		Chamfer	0.008	0.010	0.013	0.015	0.020	0.025	0.030
Hardened Steels 45 - 50HRC	H	Deburr	0.010	0.013	0.015	0.025	0.035	0.045	0.054
		Chamfer	0.005	0.007	0.008	0.013	0.018	0.023	0.027
Hardened Steels 50 - 55HRC	H	Deburr	0.008	0.010	0.011	0.020	0.030	0.040	0.050
		Chamfer	0.004	0.005	0.006	0.010	0.015	0.020	0.025
Non Ferrous	N	Deburr	0.015	0.020	0.025	0.030	0.040	0.050	0.050
		Chamfer	0.008	0.010	0.013	0.015	0.020	0.025	0.025

Please note: These are recommended starting conditions. However, please adjust the feed to suit the surface finish requirements.



# TuffCut® GP Series FBPM

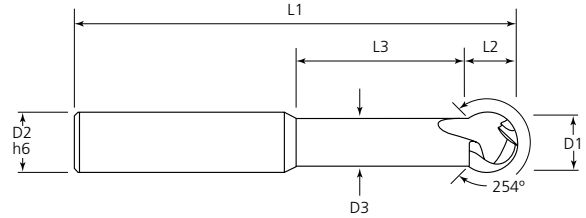
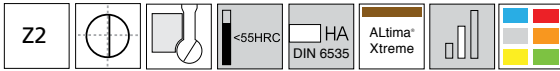

**NEW Products**

Nouveaux produits  
Neue Produkte  
Nuovi Prodotti  
Nowe Produkty

Tool Number	D1	D2	D3	L1	L2	L3	R
FBPM 03N3H	3.0	4.0	2.4	50.0	2.5	9.0	R1.5
FBPM 04N3H	4.0	4.0	3.2	50.0	3.5	11.5	R2.0
FBPM 05N3H	5.0	6.0	4.0	57.0	4.5	14.0	R2.5
FBPM 06N3H	6.0	6.0	4.8	64.0	5.4	16.6	R3.0
FBPM 08N3H	8.0	8.0	6.4	63.0	7.4	21.6	R4.0
FBPM 10N3H	10.0	10.0	8.0	72.0	9.4	26.6	R5.0
FBPM 12N3H	12.0	12.0	9.6	83.0	11.4	31.6	R6.0

## TuffCut® GP Series FBPM

Recommended cutting data | Conditions de coupe recommandées | Empfohlene Schnittdaten | Dati di taglio Raccomandati | Zalecane Parametry

### Recommended Speeds and Depths of Cut by Material Group

Workpiece Material Group	Material Type	Ap			Roughing		Finishing	
		Ae			0.05 - 0.1 x D		0.02 - 0.05 x D	
		Coolant			0.2 - 0.3 x D		0.02 - 0.05 x D	
		Max	Air	MMS	Vc-m/min			
Steels	P	Low Carbon Steels ≤180HB	○	●	●	250	280	
		Med Carbon / Alloy Steels 180-350HB	○	●	●	200	220	
		Pre-Hardened Steels 35-45HRC	○	●	●	180	200	
Stainless Steels	M	Free Machining Stainless	●	○	○	160	180	
		Austenitic Stainless	●	○	○	130	150	
		Difficult Stainless	●	○	○	100	110	
Special Alloys	S	High Temp Alloys	●	X	X	50	55	
		Titanium Alloys	●	X	X	110	120	
Cast Irons	K	Grey Cast Iron	○	●	X	220	250	
		Ductile Cast Iron	○	●	X	180	200	
Hardened Steels	H	Hardened Steels 45 - 50HRC	○	●	○	160	170	
Non-Ferrous	N	Aluminium Alloys	●	X	○	300	500	
		Brass / Bronze / Copper	●	X	○	250	400	

● Preferred ○ Possible X Not Possible

### Recommended Feed per Tooth by Material Group

Workpiece Material Group	Material Type	Tool Diameter & Radius (mm)								
		3		4		5		6		
		1.5		2		2.5		3		
		Rough	Finish	Rough	Finish	Rough	Finish	Rough	Finish	
Steels	P	Low Carbon Steels ≤180HB	0.060	0.045	0.080	0.060	0.100	0.075	0.120	0.090
		Med Carbon / Alloy Steels 180-350HB	0.060	0.045	0.080	0.060	0.100	0.075	0.120	0.090
		Pre-Hardened Steels 35-45HRC	0.054	0.045	0.072	0.060	0.090	0.075	0.108	0.090
Stainless Steels	M	Free Machining Stainless	0.054	0.045	0.072	0.060	0.090	0.075	0.108	0.090
		Austenitic Stainless	0.045	0.045	0.060	0.060	0.075	0.075	0.090	0.090
		Difficult Stainless	0.045	0.045	0.060	0.060	0.075	0.075	0.090	0.090
Special Alloys	S	High Temp Alloys	0.024	0.030	0.032	0.040	0.040	0.050	0.048	0.060
		Titanium Alloys	0.036	0.030	0.048	0.040	0.060	0.050	0.072	0.060
Cast Irons	K	Grey Cast Iron	0.060	0.045	0.080	0.060	0.100	0.075	0.120	0.090
		Ductile Cast Iron	0.054	0.045	0.072	0.060	0.090	0.075	0.108	0.090
Hardened Steels	H	Hardened Steels 45 - 50HRC	0.039	0.038	0.052	0.050	0.065	0.063	0.078	0.075
Non-Ferrous	N	Aluminium Alloys	0.075	0.045	0.100	0.060	0.125	0.075	0.150	0.090
		Brass / Bronze / Copper	0.060	0.045	0.080	0.060	0.100	0.075	0.120	0.090

Workpiece Material Group	Material Type	Tool Diameter & Radius (mm)						
		8		10		12		
		4		5		6		
		Rough	Finish	Rough	Finish	Rough	Finish	
Steels	P	Low Carbon Steels ≤180HB	0.160	0.120	0.200	0.150	0.240	0.180
		Med Carbon / Alloy Steels 180-350HB	0.160	0.120	0.200	0.150	0.240	0.180
		Pre-Hardened Steels 35-45HRC	0.144	0.120	0.180	0.150	0.216	0.180
Stainless Steels	M	Free Machining Stainless	0.144	0.120	0.180	0.150	0.216	0.180
		Austenitic Stainless	0.120	0.120	0.150	0.150	0.180	0.180
		Difficult Stainless	0.120	0.120	0.150	0.150	0.180	0.180
Special Alloys	S	High Temp Alloys	0.064	0.080	0.080	0.100	0.096	0.120
		Titanium Alloys	0.096	0.080	0.120	0.100	0.144	0.120
Cast Irons	K	Grey Cast Iron	0.160	0.120	0.200	0.150	0.240	0.180
		Ductile Cast Iron	0.144	0.120	0.180	0.150	0.216	0.180
Hardened Steels	H	Hardened Steels 45 - 50HRC	0.104	0.100	0.130	0.125	0.156	0.150
Non-Ferrous	N	Aluminium Alloys	0.200	0.120	0.250	0.150	0.300	0.180
		Brass / Bronze / Copper	0.160	0.120	0.200	0.150	0.240	0.180

## TuffCut® GP Chamfer Mills Series VCM60, VCM90

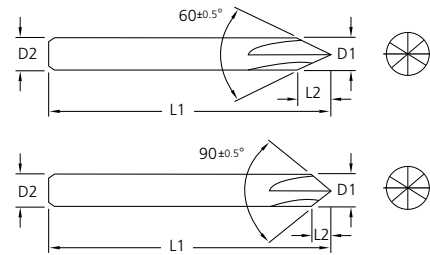
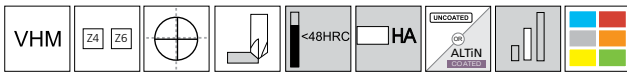

Series VCM60		Series VCM90		Tool Dimensions					
Uncoated	Coated	Uncoated	Coated	Ø D1	Ø D2	Angle	L1	L2	Z
VCM60 0400	VCM60 0400A	-	-	4.0	4.0	60°	51.0	3.3	4
-	-	VCM90 0400	VCM90 0400A	4.0	4.0	90°	51.0	1.8	4
VCM60 0600	VCM60 0600A	-	-	6.0	6.0	60°	64.0	5.0	4
-	-	VCM90 0600	VCM90 0600A	6.0	6.0	90°	64.0	2.8	4
VCM60 0800	VCM60 0800A	-	-	8.0	8.0	60°	64.0	6.8	4
-	-	VCM90 0800	VCM90 0800A	8.0	8.0	90°	64.0	3.8	4
VCM60 1000	VCM60 1000A	-	-	10.0	10.0	60°	73.0	8.5	6
-	-	VCM90 1000	VCM90 1000A	10.0	10.0	90°	73.0	4.8	6
VCM60 1200	VCM60 1200A	-	-	12.0	12.0	60°	84.0	10.0	6
-	-	VCM90 1200	VCM90 1200A	12.0	12.0	90°	84.0	5.8	6
VCM60 1600	VCM60 1600A	-	-	16.0	16.0	60°	93.0	13.5	6
-	-	VCM90 1600	VCM90 1600A	16.0	16.0	90°	93.0	7.8	6

## TuffCut® GP Corner Rounding Series ACR

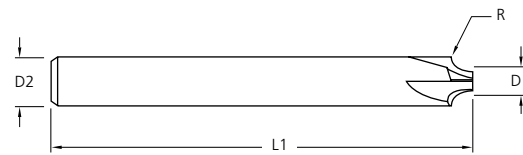

Series ACR	Tool Dimensions			
Tool No.	Ø D1	D2	L1	R
ACR0300-0.25R	2.3 / 2.4	3.0	51.0	0.25
ACR0400-0.5R	2.8 / 2.9	4.0	51.0	0.5
ACR0500-0.75R	3.3 / 3.4	5.0	57.0	0.75
ACR0500-1.0R	2.7 / 2.9	5.0	57.0	1.0
ACR0600-1.5R	2.7 / 2.9	6.0	64.0	1.5
ACR0600-2.0R	1.7 / 1.9	6.0	64.0	2.0
ACR0800-2.0R	3.7 / 3.9	8.0	64.0	2.0
ACR1000-3.0R	3.7 / 3.9	10.0	73.0	3.0
ACR1200-4.0R	3.7 / 3.9	12.0	84.0	4.0
ACR1600-5.0R	5.7 / 5.9	16.0	93.0	5.0
ACR1600-6.0R	3.7 / 3.9	16.0	93.0	6.0





XEBEC TECHNOLOGY  
Product Catalog  
2023/2024



BEAUTIFUL DEBURRING®

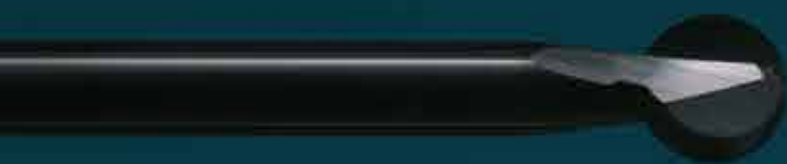

# INDEX

<b>Applications</b>	<b>3</b>
Automotive	3
Industrial Machinery	4
Aerospace	4
Orthopedic Medical Devices	4
<b>XEBEC Brush™</b>	<b>5</b>
XEBEC Brush™ Surface	7
XEBEC Brush™ Surface End Type	9
XEBEC Brush™ Surface Extra-Large	10
XEBEC Brush™ Crosshole	11
XEBEC Brush™ Crosshole Extra-Large	13
XEBEC Brush™ Crosshole Extra-Long	14
XEBEC Brush™ Wheel Type	15
<b>XEBEC Optional Tools</b>	<b>17</b>
XEBEC Floating Holder™	19
XEBEC Self-Adjusting Sleeve™	21
XEBEC Short BT Holder™	23
XEBEC Brush Length Adjustment Tool™	23
<b>XEBEC Back Burr Cutter and Deburring Tool Path™</b>	<b>25</b>
XEBEC Back Burr Cutter™	27
XEBEC Deburring Tool Path™	29
<b>XEBEC Burrless Chamfering Cutter™</b>	<b>31</b>
<b>XEBEC Ceramic Stone™</b>	<b>35</b>
XEBEC Stone™ Flexible Shaft	37
XEBEC Stone™ Mounted Point	39
Mobile Micromotor System	41
<b>Technical Information</b>	<b>42</b>
<b>About XEBEC</b>	<b>49</b>
<b>History</b>	<b>50</b>

# Applications

## Automotive

### CNC deburring of cylinder head

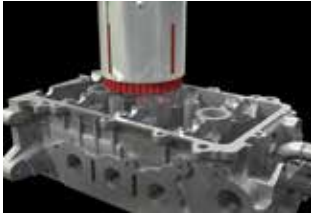

Material: ADC12  
Follows: Face milling  
Tool:  
XEBEC Brush Surface  
A11-CB100M, p. 7



VIDEO

### CNC deburring of scroll compressor



Material: Aluminum  
Follows: Face milling  
Tool:  
XEBEC Brush Surface  
A11-CB40M, p. 7



VIDEO

### CNC deburring of inverter case



Material: ADC12  
Follows: Face milling  
Tool:  
XEBEC Brush Surface  
A32-CB25M, p. 7



VIDEO

### CNC deburring of pinion gear

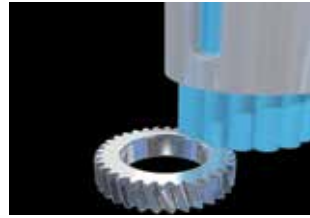

Material: S45C  
Follows: Gear hobbing  
Tool:  
XEBEC Brush Surface  
A32-CB40M, p. 7



VIDEO

### CNC removal of coating on combustor part



Material: Ceramics  
Follows: Face milling  
Tool:  
XEBEC Brush Surface  
A11-CB15M, p. 7



VIDEO

### CNC polishing of metal mold for car body panel



Material: SKD11  
Follows: End milling  
Tool:  
XEBEC Brush Surface  
A32-CB25M & A11-CB25M, p. 7



VIDEO

### CNC deburring of input shaft

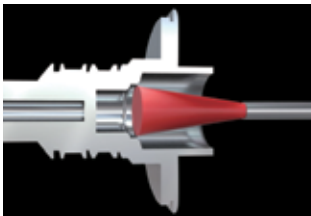

Material: SCM  
Follows: Drilling  
Tool:  
XEBEC Brush Crosshole  
CH-A12-7M-TL, p. 11



VIDEO

### CNC deburring of yoke



Material: SCM  
Follows: Drilling  
Tool:  
Back Burr Cutter & Deburring  
Tool Path, XC-58-A, p. 27



VIDEO

### Manual polishing of tire mold



Material: Aluminum  
Follows: Ball end milling  
Tool:  
XEBEC Brush Surface End Type  
A11-EB06M, p. 9



VIDEO

### CNC deburring of camshaft



Material: FCD  
Follows: Drilling  
Tool:  
Back Burr Cutter & Deburring  
Tool Path, XC-38-A, p. 27



VIDEO

### CNC deburring of differential case



Material: FCD  
Follows: Drilling  
Tool:  
Back Burr Cutter & Deburring  
Tool Path, XC-78-A, p. 27



VIDEO

### Chamfering of exterior part



Material: CFRP  
Follows: Tapping  
Tool:  
Burrless Chamfering Cutter  
XC-C-06-N, p. 33



VIDEO

■ Material names are JIS. Common names are used when the JIS name is unavailable.



## Industrial Machinery

### CNC deburring of gearbox



Material: FC250  
Follows: Face milling  
Tool:  
XEBEC Brush Surface  
A32-CB60M, p. 7



VIDEO

### CNC deburring of pipe

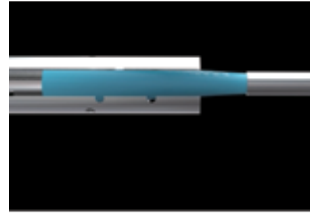

Material: Stainless steel  
Follows: Drilling  
Tool:  
XEBEC Brush Crosshole  
CH-A33-7M, p. 11



VIDEO

### CNC deburring of slide cylinder



Material: Aluminum  
Follows: End milling  
Tool:  
XEBEC Brush Surface  
A21-CB25M, p. 7



VIDEO

### CNC deburring of shaft



Material: SCM  
Follows: Threading  
Tool:  
XEBEC Brush Wheel Type  
W-A11-50, p. 15



VIDEO

### CNC roughing of brake disc



Material: SPHC  
Follows: Turning  
Tool:  
XEBEC Brush Surface  
A21-CB25M, p. 7



VIDEO

## Aerospace

### CNC polishing of turbine blade



Material: SUS630  
Follows: Ball end milling  
Tool:  
XEBEC Brush Surface  
A32-CB25M & A11-CB25M, p. 7



VIDEO

## Orthopedic Medical Devices

### CNC polishing of artificial hip joint



Material: CoCrMo  
Follows: Turning  
Tool:  
XEBEC Brush Surface  
A13-CB06M, p. 7



VIDEO

### Manual deburring of hydraulic manifold



Material: Aluminum  
Follows: Drilling  
Tool:  
XEBEC Stone Flexible Shaft  
CH-PM-6B, p. 37



VIDEO

### CNC deburring of osteosynthesis screw



Material: Titanium  
Follows: End milling  
Tool:  
XEBEC Brush Surface End Type  
A11-EB06M, p. 9



VIDEO

### Manual deburring of shaft



Material: Aluminum  
Follows: Casting  
Tool:  
XEBEC Stone Mounted Point  
AX-PM-6T, p. 39



VIDEO

### CNC deburring of spinal implant



Material: PEEK resin  
Follows: End milling  
Tool:  
Back Burr Cutter & Deburring  
Tool Path, XC-18-A, p. 27



VIDEO

Automate deburring and polishing in your CNC machine

## XEBEC Brush™

“What if we could make a brush out of the same material as ceramic grinding stones. It would be truly groundbreaking!”

And so, the ceramic brush was born. It was one of a kind; the result of a desire to challenge technological norms. Yet no one quite understood what it could be used for. Some forward-thinking users believed in its potential. Thanks to them, we found out it could remove fine burrs and improve surface roughness at the same time. They also found it easy to manage compared with conventional brushes. This resulted in us pioneering the concept of automated deburring and polishing.

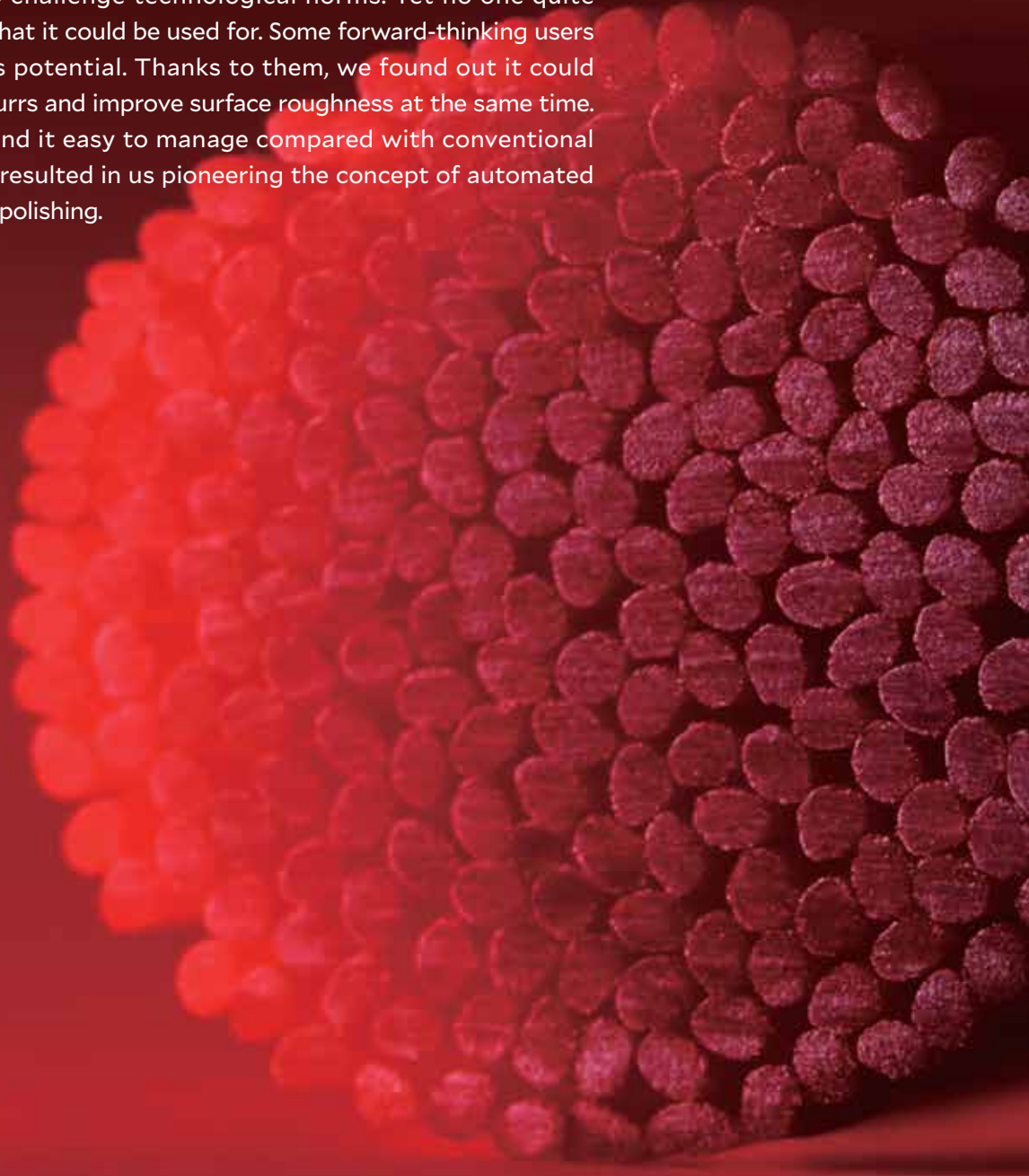

XEBEC Brush uses unique abrasive ceramic fiber material instead of abrasive grain. Each bristle consists of 1,000 ceramic fibers that work as cutting edges. Overwhelming grinding power, consistent cutting performance, and no deformation enables CNC deburring immediately after machining operations inside the same machine tool.

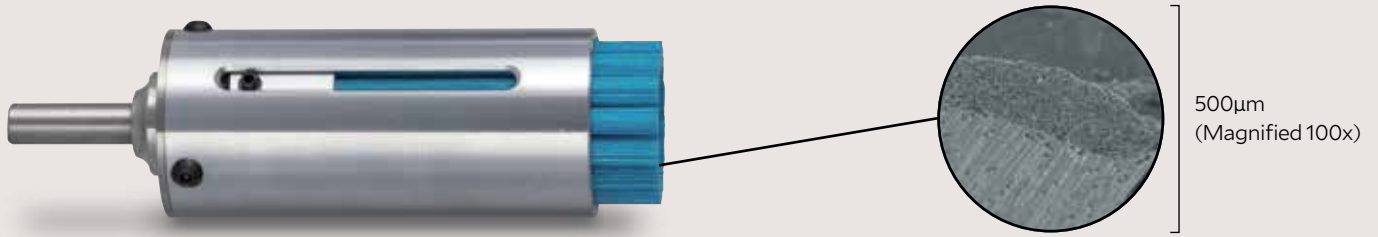

### High grinding power

The content ratio of ceramic fiber is approximately 80%. Cutting edges on the brush tips offer excellent grinding power.

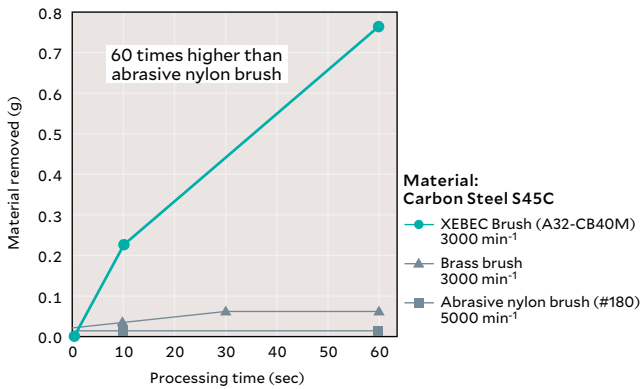

### Consistent grinding performance

New cutting edges are always exposed. Consistent grinding performance throughout due to the uniform structure of the fiber.

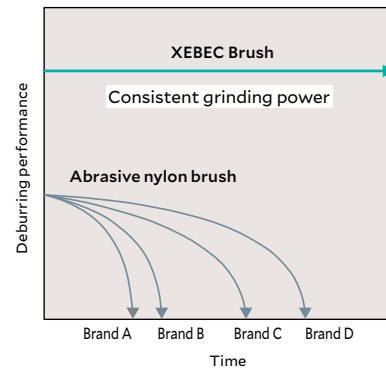

### No deformation

Maintains its straight shape and does not spread out like an old toothbrush. Easy to manage on mass production lines.

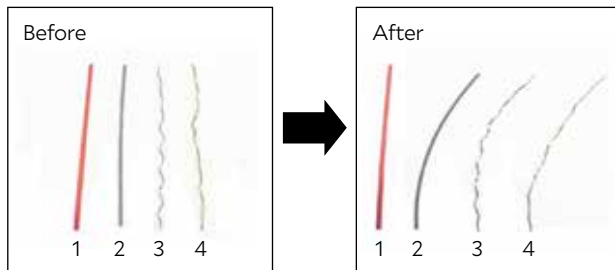

1. XEBEC Brush (A11 red bristle)
2. Abrasive nylon brush
3. Steel wire brush
4. Brass wire brush

### Optimal for polishing

The high grinding power of ceramic fiber makes this tool optimal for polishing. Achievable surface roughness is Ra = 0.1 µm (Rz = 0.4 µm).

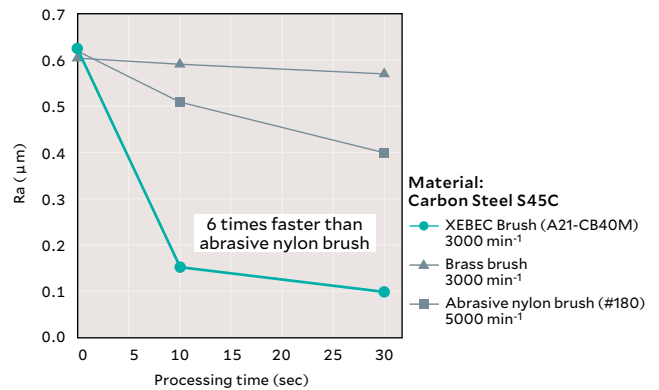

### Brush selection

Workpiece material	Resin		Copper, Brass	
			Aluminum	
			Steel	
			Stainless steel	HRSA steel
				Cast iron
				Hard material
Burr size	Micro fine burrs			
			Burr thickness (≤ 0.1 mm)	Burr thickness (0.1 - 0.2 mm)
Brush (color)	A13 (pink)	A11 (red)	A21 (white)	A32 (blue)
Grinding power	→ High			

- Not all brush colors are available in all sizes.
- HRSA (heat resistant super alloy)

### Deburring



### Polishing



# XEBEC Brush™ Surface Patented

Deburring, cutter mark removal, and surface polishing

**Applicable burr size**  
Burr thickness ≤ 0.2 mm  
(Burrs this size can be bent by fingernails)

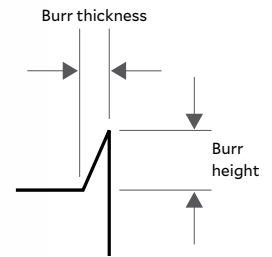

VIDEO

## Applicable equipment

This tool can be mounted on equipment shown below.



Machining center



Lathe (with live tools)



Dedicated machine



Robot

## Tool composition

Brush and sleeve are sold separately.  
Assemble brush and sleeve before use.



Brush



Sleeve

## Brushes

Brush (color)	Product code	Brush diameter (mm)	Bristle length $\ell$ (mm)	Matching sleeve	Fig.
A13 (pink)	A13-CB06M	$\phi 6$	30	S06M	1
	A13-CB15M	$\phi 15$	50	S15M-P	1
A11 (red)	A11-CB06M	$\phi 6$	30	S06M	1
	A11-CB15M	$\phi 15$	50	S15M-P	1
	A11-CB25M	$\phi 25$	75	S25M	1
	A11-CB40M	$\phi 40$	75	S40M-SD10	1
	A11-CB60M	$\phi 60$	75	S60M	1
	A11-CB100M	$\phi 100$	75	S100M	1
A21 (white)	A21-CB06M	$\phi 6$	30	S06M	1
	A21-CB15M	$\phi 15$	50	S15M-P	1
	A21-CB25M	$\phi 25$	75	S25M	1
	A21-CB40M	$\phi 40$	75	S40M-SD10	1
	A21-CB60M	$\phi 60$	75	S60M	1
	A21-CB100M	$\phi 100$	75	S100M	1
A32 (blue)	A32-CB06M	$\phi 6$	30	S06M	1
	A32-CB15M	$\phi 15$	50	S15M-P	1
	A32-CB25M	$\phi 25$	75	S25M	1
	A32-CB40M	$\phi 40$	75	S40M-SD10	1
	A32-CB60M	$\phi 60$	75	S60M	1
	A32-CB100M	$\phi 100$	75	S100M	1

- Bristle bundles are embedded in a single line on the periphery (except for  $\phi 6$  type).
- Brush size is approximate as the tip expands with rotation.
- Brushes larger than  $\phi 100$  are available by special order. Refer to page 10.

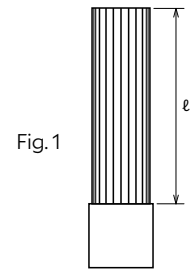

Fig. 1

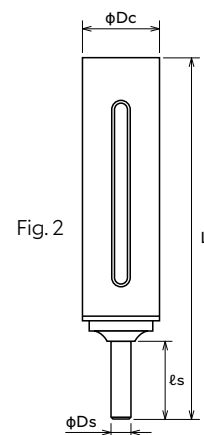

Fig. 2



MANUAL

## Sleeves

Product code	Brush dia. (mm)	External dia. Dc (mm)	Shank dia. Ds (mm)	Overall length L (mm)	Shank length $\ell s$ (mm)	Matching brush	Fig.
S06M	$\phi 6$	$\phi 10$	$\phi 6$	70	29	A13/A11/A21/A32-CB06M	2
S15M-P	$\phi 15$	$\phi 18.5$	$\phi 6$	90	29	A13/A11/A21/A32-CB15M	2
S25M	$\phi 25$	$\phi 30$	$\phi 8$	140	30	A11/A21/A32-CB25M	2
S40M-SD10	$\phi 40$	$\phi 45$	$\phi 10$	140	30	A11/A21/A32-CB40M	2
S60M	$\phi 60$	$\phi 65$	$\phi 12$	150	35	A11/A21/A32-CB60M	2
S100M	$\phi 100$	$\phi 110$	$\phi 16$	162	40	A11/A21/A32-CB100M	2

- Overall length L is sleeve length not including brush projection.
- The case of the S15M-P is made of fiber-reinforced plastic (FRP).

Refer to p. 43 to select brush color

## Applications

Higher quality automated deburring

### Cylinder head



Material: Aluminum  
Follows: Face milling  
Tool: A11-CB100M

#### Before

Abrasive nylon brush was used. It was time-consuming and not able to remove all burrs.

#### After

All burrs are removed by high grinding power. Quality is stable. The cycle time is shortened by a high feed rate.

Automation of time-consuming polishing

### Metal mold



Material: Hard material  
Follows: End milling  
Tool: A11-CB25M

#### Before

40 minutes hand polishing per workpiece. Uneven quality resulted in complaints.

#### After

Shortened the polishing time to one minute per workpiece by automation. Achieved uniform polishing quality.

## How to use

### Rotational speed

Recommended parameters differ depending on brush size. Refer to the chart below for starting parameters for each brush size.

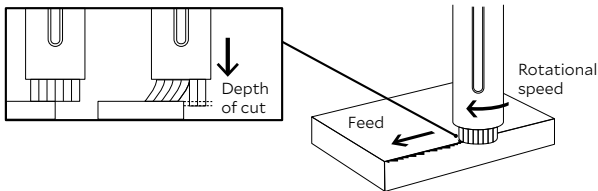

### Rotational direction

Set the rotational direction so that the brush pushes the burrs up from below.

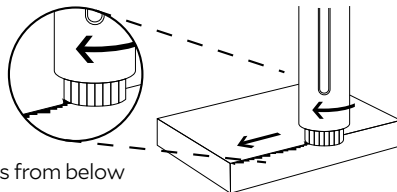

Upcut against burrs from below

### Feed rate - Deburring

Burr thickness: 0.05 mm  
(Very easily bent by fingernails) → 4000 mm/min

Burr thickness: 0.1 mm  
(Easily bent by fingernails) → 2500 mm/min

### Feed rate - Polishing

Cutter mark removal, polishing → 250 - 850 mm/min

### Depth of cut - Vertical burrs

Formed by end milling & drilling  
(Are vertical to brush tip) → 0.5 mm

### Depth of cut - Horizontal burrs

Formed by face milling  
(Are horizontal to brush tip) → 1.0 mm

### Depth of cut - Polishing

Cutter mark removal, polishing → 0.3 - 0.5 mm

## Starting parameters

Product code	Rotational speed (min <sup>-1</sup> )			Depth of cut (mm)			Feed rate (mm/min)			Brush protrusion (mm)	
	Deburring	Cutter mark removal, polishing	Maximum	Vertical burrs	Horizontal burrs	Cutter mark removal, polishing	Burr thickness 0.05 mm	Burr thickness 0.1 mm	Cutter mark removal, polishing	Deburring	Cutter mark removal, polishing
A13-CB06M A11-CB06M A21-CB06M	8000	10000	10000	0.5	0.5	0.3	4000	2500	250	10	10
A32-CB06M	8000	10000	10000	0.3	0.3	0.3	4000	2500	250	10	10
A13-CB15M	4800	6000	6000	1.0	1.0	0.5	4000	2500	450	10	10
A11-CB15M A21-CB15M A32-CB15M	4800	6000	6000	0.5	1.0	0.5	4000	2500	450	10	10
A11-CB25M A21-CB25M A32-CB25M	4000	5000	5000	0.5	1.0	0.5	4000	2500	700	15	10
A11-CB40M A21-CB40M A32-CB40M	2400	3000	3000	0.5	1.0	0.5	4000	2500	800	15	10
A11-CB60M A21-CB60M A32-CB60M	1600	2000	2000	0.5	1.0	0.5	4000	2500	850	15	10
A11-CB100M A21-CB100M A32-CB100M	960	1200	1200	0.5	1.0	0.5	4000	2500	850	15	10

■ Plastic workpieces may deform or discolor. If this occurs, reducing rotational speed to approximately 10% of the starting parameter may solve the problem.



# XEBEC Brush™ Surface End Type

Cutter mark removal and polishing on sealing surfaces

**Applicable burr size**  
 Burr thickness ≤ 0.1 mm  
 (Burs this size can be easily bent by fingernails)

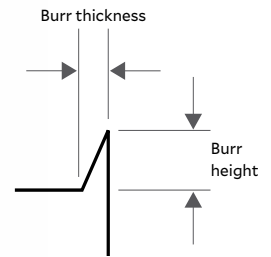

VIDEO

## Applicable equipment

This tool can be used with equipment that controls rotational speed.



Machining center



Lathe (with live tools)



Dedicated machine



Robot



Rotary tool (electric)

## Brushes

Brush (color)	Product code	Brush dia. (mm)	Shank dia. Dc (mm)	Bristle length ℓ (mm)	Overall length L (mm)	Standard rotational speed (min <sup>-1</sup> )	Maximum rotational speed (min <sup>-1</sup> )	Fig.
A13 (pink)	A13-EB01S	φ1	φ3	15	52	7000 - 12000	15000	3
	A13-EB015S	φ1.5	φ3	15	52	7000 - 12000	15000	3
	A13-EB02S	φ2	φ3	15	52	7000 - 12000	15000	3
	A13-EB025S	φ2.5	φ3	15	52	7000 - 12000	15000	3
	A13-EB03M	φ3	φ3	30	67	4000	6000	3
A11 (red)	A11-EB01S	φ1	φ3	15	52	7000 - 12000	15000	3
	A11-EB015S	φ1.5	φ3	15	52	7000 - 12000	15000	3
	A11-EB02S	φ2	φ3	15	52	7000 - 12000	15000	3
	A11-EB025S	φ2.5	φ3	15	52	7000 - 12000	15000	3
	A11-EB06M	φ5	φ3	20	57	7000	12000	4
	A21 (white)	A21-EB06M	φ5	φ3	20	57	7000	12000
A32 (blue)	A32-EB06M	φ5	φ3	20	57	7000	12000	4

■ Brush size is approximate as the tip expands with rotation.

## Precautions for use

The grinding load must be less than 2 N for hand use.  
 The brush will break if:

- used beyond the maximum rotational speed
- used beyond the maximum indentation load
- used with a pneumatic rotary tool

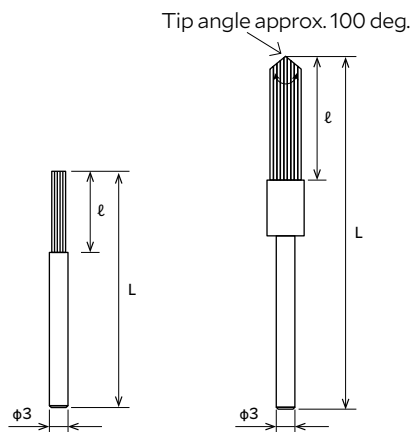

Fig. 3

Fig. 4

A11-EB06M  
 A21-EB06M  
 A32-EB06M



MANUAL

Refer to p. 45 to select brush color

# XEBEC Brush™ Surface Extra-Large Patented

Deburring, cutter mark removal, surface polishing ( $\geq 100$  mm)

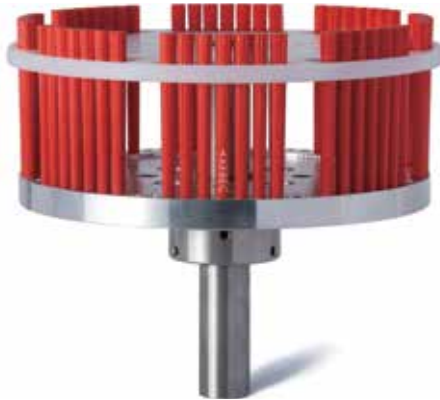

**Applicable burr size**  
Burr thickness  $\leq 0.2$  mm  
(Burrs this size can be bent by fingernails)

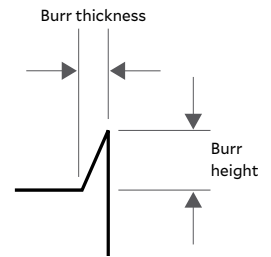

VIDEO

## Applicable equipment

This tool can be mounted on equipment shown below.



Machining center



Lathe (with live tools)



Dedicated machine

## Tool composition

The brush main unit and slide ring are separate items. Assemble the main unit and slide ring before use.

Brush



Slide ring

- Ring
- Base holder
- Shank

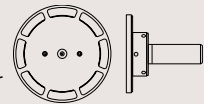

## Brushes

Brush (color)	Product code	Brush diameter (mm)	Bristle length $\ell$ (mm)	Matching slide ring (Product code)	Fig.
A11 (red)	A11-CB125M	$\phi 125$	75	SR125M	5
	A11-CB165M	$\phi 165$	75	SR165M	5
	A11-CB200M	$\phi 200$	75	SR200M	5
A21 (white)	A21-CB125M	$\phi 125$	75	SR125M	5
	A21-CB165M	$\phi 165$	75	SR165M	5
	A21-CB200M	$\phi 200$	75	SR200M	5
A32 (blue)	A32-CB125M	$\phi 125$	75	SR125M	5
	A32-CB165M	$\phi 165$	75	SR165M	5
	A32-CB200M	$\phi 200$	75	SR200M	5

■ Brush size is approximate as the tip expands with rotation.

## Slide rings

Product code	Brush diameter (mm)	Outer dia. Dc (mm)	Shank diameter (mm)	Overall length L (mm)	Fig.
SR125M	$\phi 125$	$\phi 135$	$\phi 25$	187	5
SR165M	$\phi 165$	$\phi 176$	$\phi 25$	187	5
SR200M	$\phi 200$	$\phi 211$	$\phi 25$	187	5

- The slide ring consists of a ring, base holder and shank.
- Base holder and shank sizes are the same for all brush diameters. Ring size varies with brush diameter.
- Combined weights of brushes and slide rings are:  $\phi 125$ : 1920 g,  $\phi 165$ : 2320 g and  $\phi 200$ : 2750 g.



MANUAL

Fig. 5

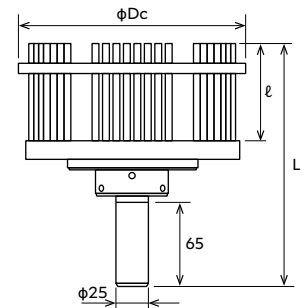

## Starting parameters

Product code	Rotational speed (min <sup>-1</sup> )			Depth of cut (mm)			Feed rate (mm/min)			Brush protrusion (mm)	
	Deburring	Cutter mark removal, polishing	Maximum	Vertical burrs	Horizontal burrs	Cutter mark removal, polishing	Burr thickness 0.05 mm	Burr thickness 0.1 mm	Cutter mark removal, polishing	Deburring	Cutter mark removal, polishing
A11-CB125M A21-CB125M A32-CB125M	800	1000	1000	0.5	1.0	0.5	4000	2500	700	15	10
A11-CB165M A21-CB165M A32-CB165M	600	750	750	0.5	1.0	0.5	4000	2500	700	15	10
A11-CB200M A21-CB200M A32-CB200M	480	600	600	0.5	1.0	0.5	4000	2500	650	15	10

■ In event of problems, refer to p. 43 (XEBEC Brush Surface) for possible adjustments.

Refer to p. 43 to select brush color

# XEBEC Brush™ Crosshole

Deburring, cutter mark removal, polishing on inner diameters & counterbores ( $\leq \phi 20$  mm)

## Applicable burr size

Burr thickness  $\leq 0.1$  mm  
(Burs this size can be easily bent by fingernails)

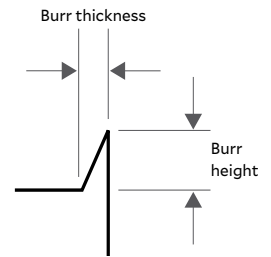

VIDEO

## Applicable equipment

This tool is used on equipment with rotational speed control ( $> 6500$  min<sup>-1</sup>).



Machining center



Lathe (with live tools)



Dedicated machine



Robot



Rotary tool (electric)

## Brushes

Brush (color)	Product code	Brush dia. (mm)	Shank dia. Dc (mm)	Shank dia. Ds (mm)	Bristle length $\ell$ (mm)	Overall length L (mm)	Maximum rotational speed (min <sup>-1</sup> )	Target hole diameter (mm)	Fig.
A12 (red)	CH-A12-1.5M	$\phi 1.5$	$\phi 2.5$	$\phi 3$	50	120	20000	$\phi 3.5 - 5$	6
	CH-A12-3M-TL	$\phi 3$	$\phi 4$	$\phi 3$	50	120	14000	$\phi 5 - 8$	6
	CH-A12-3L-TL	$\phi 3$	$\phi 4$	$\phi 4$	50	170	12000	$\phi 5 - 8$	6
	CH-A12-5M-TL	$\phi 5$	$\phi 6$	$\phi 6$	50	120	14000	$\phi 8 - 10$	6
	CH-A12-5L-TL	$\phi 5$	$\phi 6$	$\phi 6$	50	170	12000	$\phi 8 - 10$	6
	CH-A12-7M-TL	$\phi 7$	$\phi 8$	$\phi 6$	50	120	14000	$\phi 10 - 20$	6
	CH-A12-7L-TL	$\phi 7$	$\phi 8$	$\phi 8$	50	170	12000	$\phi 10 - 20$	6
	CH-A12-11M	$\phi 11$	$\phi 12$	$\phi 12$	50	120	14000	$\phi 14 - 20$	6
CH-A12-11L	$\phi 11$	$\phi 12$	$\phi 12$	50	170	12000	$\phi 14 - 20$	6	
A33 (blue)	CH-A33-3M	$\phi 3$	$\phi 4$	$\phi 3$	60	130	14000	$\phi 5 - 8$	6
	CH-A33-3L	$\phi 3$	$\phi 4$	$\phi 4$	60	180	12000	$\phi 5 - 8$	6
	CH-A33-5M	$\phi 5$	$\phi 6$	$\phi 6$	60	130	14000	$\phi 8 - 10$	6
	CH-A33-5L	$\phi 5$	$\phi 6$	$\phi 6$	60	180	12000	$\phi 8 - 10$	6
	CH-A33-7M	$\phi 7$	$\phi 8$	$\phi 6$	60	130	14000	$\phi 10 - 14$	6
	CH-A33-7L	$\phi 7$	$\phi 8$	$\phi 8$	60	180	12000	$\phi 10 - 14$	6
	CH-A33-11M	$\phi 11$	$\phi 12$	$\phi 12$	60	130	14000	$\phi 14 - 20$	6
	CH-A33-11L	$\phi 11$	$\phi 12$	$\phi 12$	60	180	12000	$\phi 14 - 20$	6

■ Brush size is approximate as the tip expands with rotation.

## Precautions for use

The shank must be inserted  $\geq 30$  mm in the holder to secure it properly.

The brush will break if:

- used beyond the maximum rotational speed
- used with a pneumatic rotary tool
- rotated outside of the bore (outside workpiece)
- used with brush tip  $< 20$  mm inside bore

The brush may break when used with:

- off-center or angled crossholes
- t-shaped holes, when secondary bore diameter  $\geq$  main bore
- crossholes, when secondary bore diameter  $\geq 70\%$  main bore

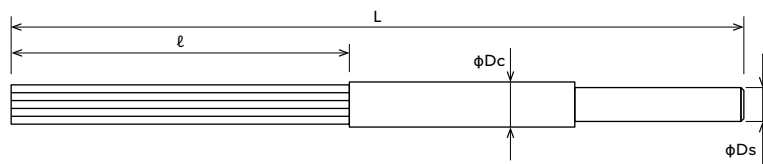

Fig. 6

Refer to p. 46 to select brush color



## Applications

### Automation of crosshole deburring

#### Input shaft

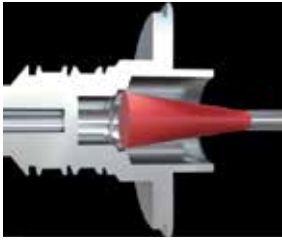

**Before**  
Manual deburring by abrasive nylon brush. Not all burrs were removed and output was low.

**After**  
A dedicated machine is used to automate deburring. All burrs are removed by high grinding power. Quality is stable.

Material: SCM  
Follows: Drilling  
Tool: CH-A12-7M-TL

### Automation of crosshole deburring

#### Valve case



**Before**  
Manual deburring by cutter was time-consuming. Cutter left scratches on inner surface.

**After**  
Deburring inside the machine reduced cycle time significantly. No scratching on inner surface and finish quality is stable.

Material: Resin  
Follows: Drilling  
Tool: CH-A12-5M-TL

## How to use

**Caution:** Rotating the brush outside of the bore may damage the brush and cause injury to the operator.

Step 1 Step 2 Step 3 Step 4 Step 5 Step 6

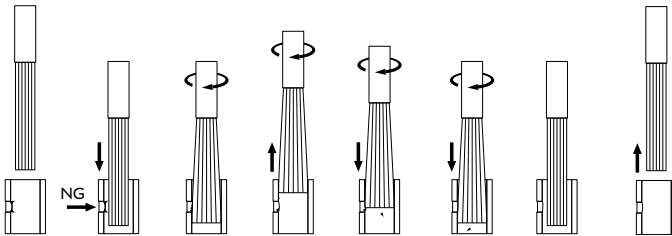

1. Insert the brush stationary into the bore.
2. Rotate the tool once past the crosshole.
3. Machine while pulling the brush back.
4. Machine while pushing the brush forward.
5. Stop the brush rotation.
6. Remove the brush when it is stationary.

## Machining parameter adjustments

### Rotational speed

Brush performance can be optimized by adjusting rotational speed in accordance with brush size, target hole diameter and brush wear. Refer below for recommended rotational speeds.

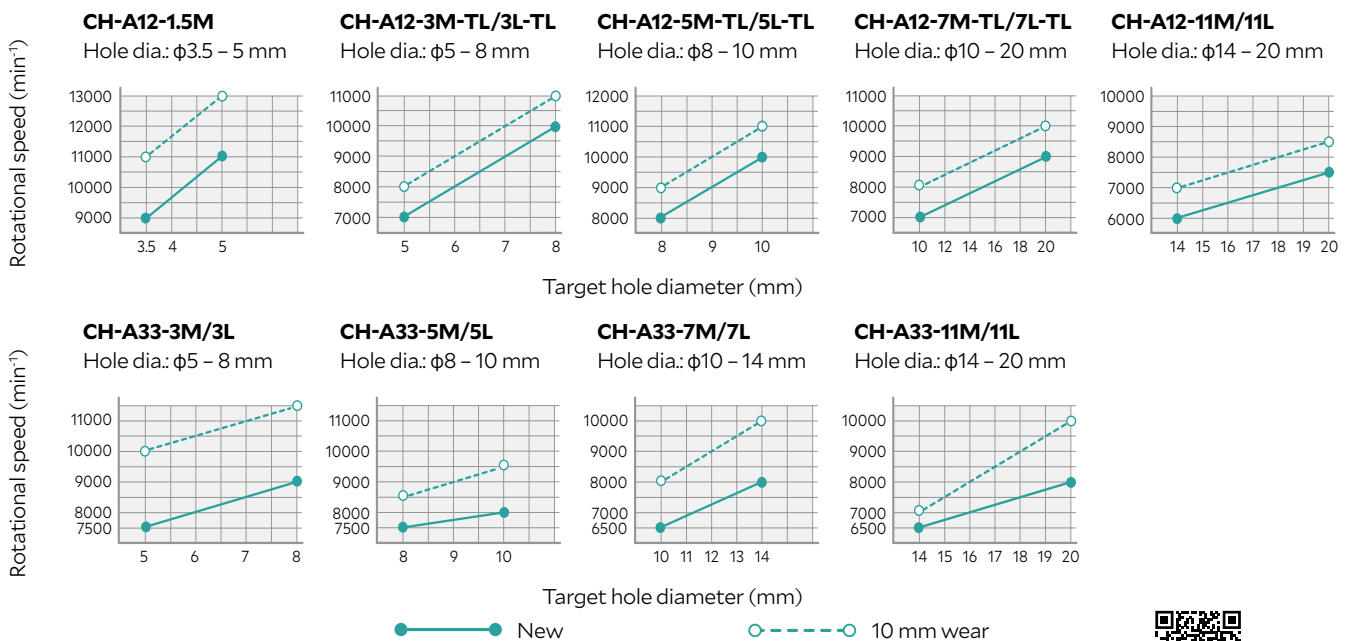

### Feed rate

300 mm/min

### Rotational direction

Uniform deburring and edge quality can be achieved by rotating the tool in both clockwise and counter-clockwise directions.



MANUAL

# XEBEC Brush™ Crosshole Extra-Large

Deburring, cutter mark removal, polishing on inner diameters & counterbores ( $\geq \phi 20$  mm)

**Applicable burr size**  
 Burr thickness  $\leq 0.1$  mm  
 (Burs this size can be easily bent by fingernails)

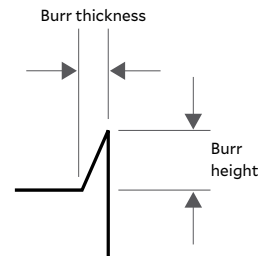

VIDEO

## Applicable equipment

This tool is used on equipment with rotational speed control ( $> 4000$  min<sup>-1</sup>).



Machining center



Lathe (with live tools)



Dedicated machine



Robot

## Tool composition

Brush and shank are sold separately. Assemble before use.

Brush



Shank



## Brushes

Brush (color)	Product code	Brush dia. (mm)	Bristle length $\ell$ (mm)	Shank insertion depth $d_s$ (mm)	Max. rotational speed (min <sup>-1</sup> )	Target hole diameter (mm)	Matching shank	Fig.
A34 (dark blue)	CH-A34-15	$\phi 15$	60	10	9000	$\phi 20 - 25$	CH-SH-6	7
	CH-A34-20	$\phi 20$	60	16	9000	$\phi 25 - 30$	CH-SH-8	7
	CH-A34-25	$\phi 25$	60	16	9000	$\phi 30 - 35$	CH-SH-8	7

- Brush size is approximate as the tip expands with rotation.
- Overall length of assembled brush and shank is 150 mm.

## Shanks

Product code	Shaft dia. $D_s$ (mm)	Shank length $\ell_s$ (mm)	Matching brush	Fig.
CH-SH-6	$\phi 6$	80	CH-A34-15	8
CH-SH-8	$\phi 8$	86	CH-A34-20, CH-A34-25	8



MANUAL

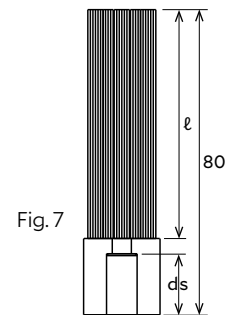

Fig. 7

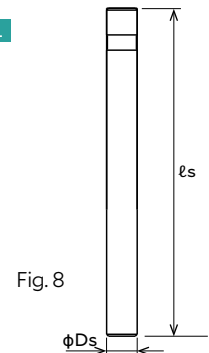

Fig. 8

## Precautions for use

The shank must be inserted  $\geq 30$  mm in the holder to secure it properly.

The brush will break if:

- used beyond the maximum rotational speed
- used with a pneumatic rotary tool
- rotated outside of the bore (outside workpiece)
- used with brush tip  $< 20$  mm inside bore

The brush may break when used with:

- crossholes larger than  $\phi 12$

Contact XEBEC technical support before using on crossholes  $> \phi 12$ .

## Machining parameters

Brush performance can be optimized by adjusting rotational speed in accordance with brush size, target hole diameter, and brush wear. Refer below for recommended rotational speeds.

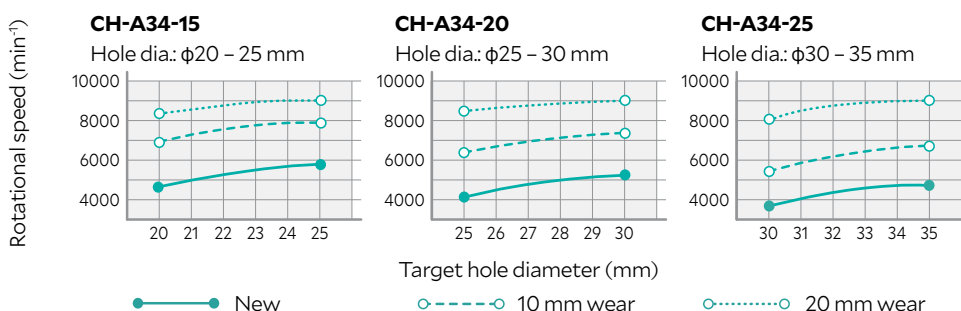

**Rotational speed:**

7000 min<sup>-1</sup>

**Feed rate:**

300 mm/min

**Rotational direction:**

Uniform deburring and edge quality can be achieved by rotating the tool in both clockwise and counter-clockwise directions.

**Applicable materials:**

Plastics, nonferrous materials, steel, stainless steel.

Refer to p. 12 for 'How to use'

# XEBEC Brush™ Crosshole Extra-Long Patented

Deburring, cutter mark removal, polishing on bores over  $\phi 150$  mm in depth

Custom-made item

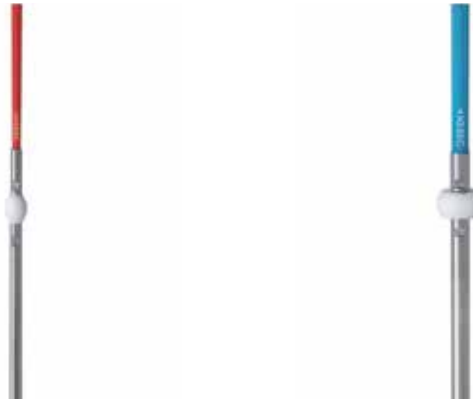

**Applicable burr size**  
 Burr thickness  $\leq 0.1$  mm  
 (Burrs this size can be easily bent by fingernails)

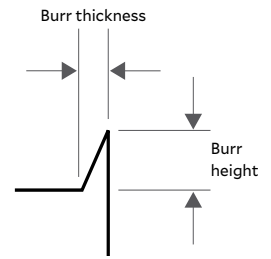

## Applicable equipment

This tool is used on full cover type equipment with rotational speed control ( $> 6500 \text{ min}^{-1}$ ).



Machining center



Lathe (with live tools)



Dedicated machine

## Tool composition

Brush, collar and shank are sold separately. Assemble before use.

## Brushes

Brush (color)	Product code	Brush diameter (mm)	Shank diameter $D_s$ (mm)	Overall length L (mm)	Maximum rotational speed ( $\text{min}^{-1}$ )
A12 (red)	*	$\phi 3$	$\phi 4$	400	12000
	*	$\phi 5$	$\phi 6$	400	12000
	*	$\phi 7$	$\phi 8$	400	12000
	*	$\phi 11$	$\phi 12$	400	12000
A33 (blue)	*	$\phi 3$	$\phi 4$	410	12000
	*	$\phi 5$	$\phi 6$	410	12000
	*	$\phi 7$	$\phi 8$	410	12000
	*	$\phi 11$	$\phi 12$	410	12000

- This is a custom-made item. Contact XEBEC technical support for details.
- Brush size is approximate as the tip expands with rotation.

## Precautions for use

The brush will break if:

- used beyond the maximum rotational speed
- used with a pneumatic rotary tool
- rotated outside of the bore (outside workpiece)

The brush may break when used with:

- off-center or angled crossholes
- t-shaped holes, when the secondary bore diameter is  $> 50\%$  of the main bore
- crossholes, when the secondary bore diameter is  $> 25\%$  of the main bore



MANUAL

Refer to p. 12 for machining parameters

Refer to p. 46 to select brush color

# XEBEC Brush™ Wheel Type

Deburring, polishing on inner diameters, side walls, and outside diameter threads

**Applicable burr size**  
 Burr thickness ≤ 0.1 mm  
 (Burs this size can be easily bent by fingernails)

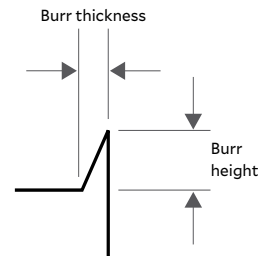

VIDEO

## Applicable equipment

This tool can be mounted on equipment shown below.



Machining center



Lathe (with live tools)



Dedicated machine



Robot

## Tool composition

Brush and shank are sold separately. Assemble before use.

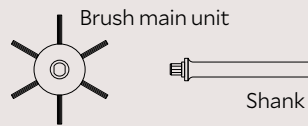

## Brushes

Brush (color)	Product code	Brush diameter (mm)	Number of bundles	Matching shank	Fig.
A11 (red)	W-A11-50	φ50	6	W-SH-M/L	9
	W-A11-75	φ75	6		

## Shanks

Product code	Shank diameter D <sub>s</sub> (mm)	Shank length ℓ <sub>s</sub> (mm)	Fig.
W-SH-M	φ8	70	10
W-SH-L	φ12	150	10

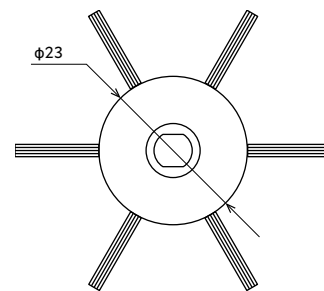

Fig. 9

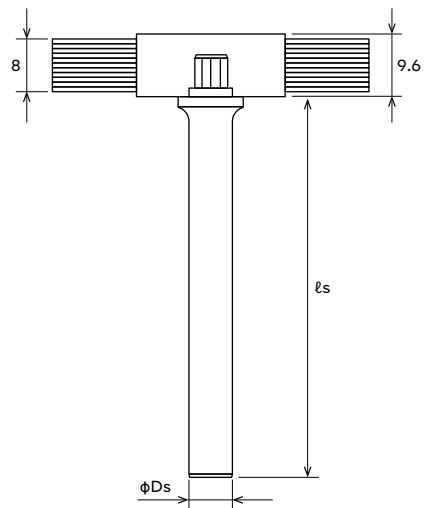

Fig. 10

## Applications

### Automation of thread deburring

#### Output shaft



#### Before

A file was used to manually deburr the thread but failed to remove all burrs. Quality was unstable.

#### After

All burrs are removed and quality is stable.

Material: SCM  
Follows: Turning  
Tool: W-A11-50

### Automated deburring of face

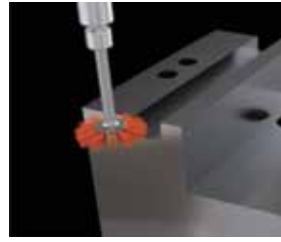

#### Before

Burrs formed on the face were removed manually.

#### After

Burrs are completely removed inside the machining center.

Material: S50C  
Follows: End milling  
Tool: W-A11-50

## How to use

As shown in the drawing at right, the best approach to removing burrs formed on surface A is to place the center of the brush at a 45-degree angle to the edge. Burrs are removed by rotating the brush both clockwise and counter-clockwise.

If this is not possible, position the brush as show at far right. The brush should also be rotated in both clockwise and counter-clockwise directions.

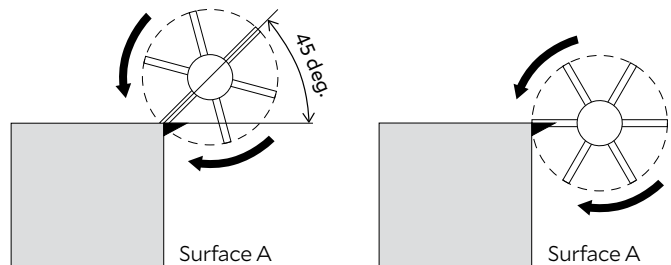

## Machining parameters

### Starting parameters

Product code	Cutting speed (m/min)	Rotational speed (min <sup>-1</sup> )	Feed per bundle (mm/bundle)	Depth of cut (mm)	Feed (mm/min)
W-A11-50	250	1600	0.5	0.2	4800
W-A11-75	250	1000	0.5	0.2	3000

### Maximum parameters

Product code	Cutting speed (m/min)	Maximum rotational speed (min <sup>-1</sup> )	Feed per bundle (mm/bundle)	Depth of cut (mm)
W-A11-50 W-A11-75	150 - 350	3000	≤ 1.5	≤ 0.5

■ Bristle stiffness increases as brushes shorten with wear. Reduce the depth of cut if bristles break.



MANUAL

# XEBEC Optional Tools

## XEBEC Optional Tools

Reduce the burden of adjusting for brush wear and achieve more consistent deburring and polishing results.



Holder with brush



### XEBEC Floating Holder™

A built-in spring helps to maintain stable load, reducing the frequency of wear offsets and brush protrusion length adjustments.



Floating holder in use



VIDEO



Sleeve with brush



### XEBEC Self-Adjusting Sleeve™

A built-in gear mechanism automatically adjusts brush protrusion length, reducing human error and providing consistent machining performance.



Self-adjusting sleeve in use



VIDEO



Brush in setter tool



### XEBEC Brush Length Adjustment Tool™

A tool for quick in-machine brush length adjustment.

# XEBEC Floating Holder™ Straight Shank Type BT Shank Type Patented

Straight Shank Type used with XEBEC Brush Surface (φ6 – 100)

A built-in spring helps to maintain stable load, reducing the frequency of wear offsets and brush protrusion length adjustments.

BT Shank Type used with XEBEC Brush Surface (φ6 – 25)



VIDEO

## Applicable equipment [Straight Shank Type]

This holder can be used on equipment shown below.



Machining center



Lathe (with live tools)



Dedicated machine



Robot

## Applicable equipment [BT Shank Type]

This holder can be used with machine tools that are compatible with BT30/40 shanks.

### Straight Shank Type

Product code	Matching brush dia. (mm)	Sleeve shank diameter (mm)	Maximum rotational speed (min <sup>-1</sup> )	Attachments	Fig.
FH-ST12-SL10	φ6	φ6 (use with bush 1●)	10000	1. φ6 bush 2. φ8 bush 3. Low-pressure spring 4. Standard spring◆ 5. High-pressure spring	11
	φ15	φ6 (use with bush 1●)	6000		
	φ25	φ8 (use with bush 2●)	5000		
	φ40	φ10	3000		
FH-ST20-60	φ60	φ12	2000		
FH-ST20-100	φ100	φ16	1200	φ16 bush	12

- ◆ Installed when shipped.
- Attachments included when shipped.
- Optional φ3 bush is available.
- Refer to p. 20 for the spring load.

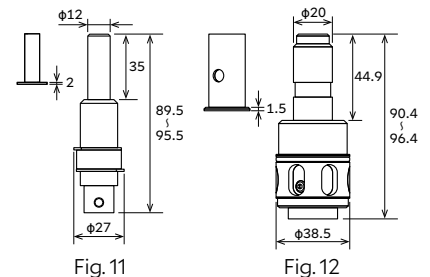

### BT Shank Type

Product code	Matching brush dia. (mm)	Sleeve shank diameter (mm)	Maximum rotational speed (min <sup>-1</sup> )	Length under gauge line (mm)	Fig.
FH-BT30	φ6	φ6 (with φ6 bush○)	10000	75	13
	φ15	φ6 (with φ6 bush○)	6000		
	φ25	φ8	5000		
FH-BT40	φ6	φ6 (with φ6 bush○)	10000	60	14
	φ15	φ6 (with φ6 bush○)	6000		
	φ25	φ8	5000		

- φ6 bush sold separately.
- Refer to p. 20 for the spring load.

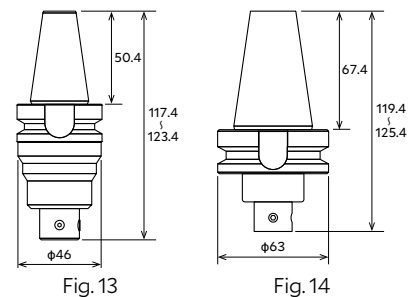

### Precautions for use

- Lower the tool vertically onto the workpiece.
- The tool cannot be used on surfaces that are discontinuous or have protrusions.
- The tool may not function correctly on a horizontal machining center when spring load is low.



## Mechanism

This tool has a built-in spring. The spring is compressed when the brush contacts the workpiece surface.

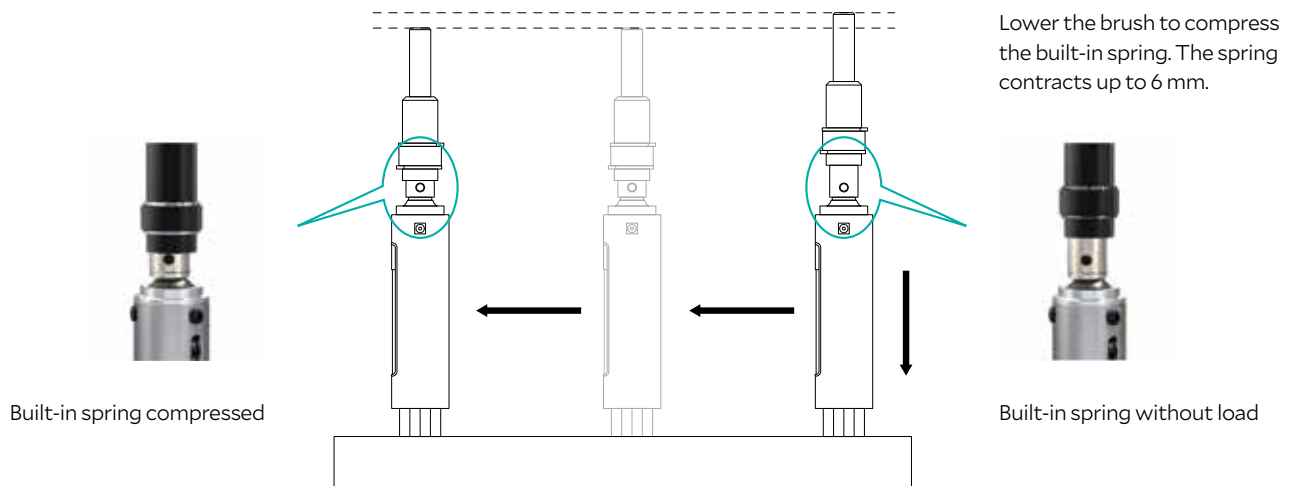

## How to use

### Product in use

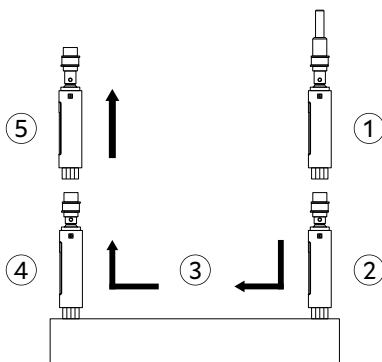

The diagram to the left shows how to use the tool effectively.

1. Approach the workpiece surface from above without rotating the brush.
2. Set the depth of cut and compress the spring.
3. Rotate the brush and start feeding with the spring compressed.
4. Stop rotation and feed when finished machining.
5. Remove the brush upward from the workpiece surface.

### Unacceptable workpiece shapes



Avoid cavities and protrusions to ensure proper operation of the floating mechanism.

### FH-ST12-SL10

Spring type	Outer diameter (mm)	Spring constant (N/mm)	Overall length (mm)	Load by stroke (N)	
				0 mm	6 mm
Standard spring (installed)	φ10	0.30	40	4.5	6.3
Low-pressure spring (attachment)	φ10	0.30	30	1.5	3.3
High-pressure spring (attachment)	φ10	0.55	39	7.2	10.5
Maximum load spring (sold separately)	φ10	3.03	30	15.2	33.4

### FH-ST20-60/100 FH-BT30/40

Load adjustment	Load by stroke (N)		Load adjustment screw position
	0 mm	6 mm	
Standard float	2	6	When load adjustment screw is flush with shaft end.
Higher float	6	10	When load adjustment screw is fully inside shaft.



MANUAL

# XEBEC Self-Adjusting Sleeve™ Patented

Used with  
XEBEC Brush Surface (φ6 – 40)

A built-in gear mechanism automatically adjusts brush protrusion length, reducing human error and providing consistent machining performance.



VIDEO

## Applicable equipment

This tool is used on equipment capable of precise angular control of the sleeve.



Machining center



Dedicated machine



Robot

## Tool composition

Consists of a sleeve and rack gear. Brushes are sold separately.

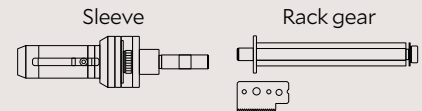

## Sleeves

Product code	Matching brush	Sleeve outer dia. Dc (mm)	Maximum outer dia. Df (mm)	Shank diameter Ds (mm)	Overall length L (mm)	Shank length ℓs (mm)	Main body mass (g)	Maximum rotational speed (min <sup>-1</sup> )	Fig.
XP-AUT06M	A13-CB06M	φ14.2	φ37	φ10	124.1	35.0	220	10000	15
	A11-CB06M								
	A21-CB06M								
	A32-CB06M								
XP-AUT15M	A13-CB15M	φ23.4	φ37	φ10	136.3	35.0	270	6000	15
	A11-CB15M								
	A21-CB15M								
	A32-CB15M								
XP-AUT25M	A11-CB25M	φ34.6	φ60	φ16	189.0	41.5	795	5000	15
	A21-CB25M								
	A32-CB25M								
XP-AUT40M	A11-CB40M	φ50.0	φ60	φ16	189.0	41.5	910	3000	15
	A21-CB40M								
	A32-CB40M								

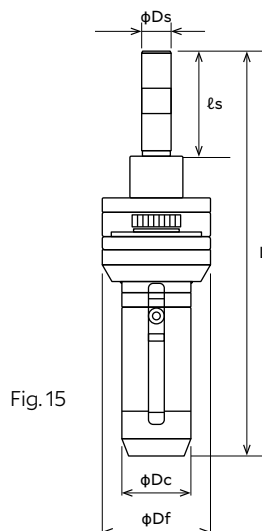
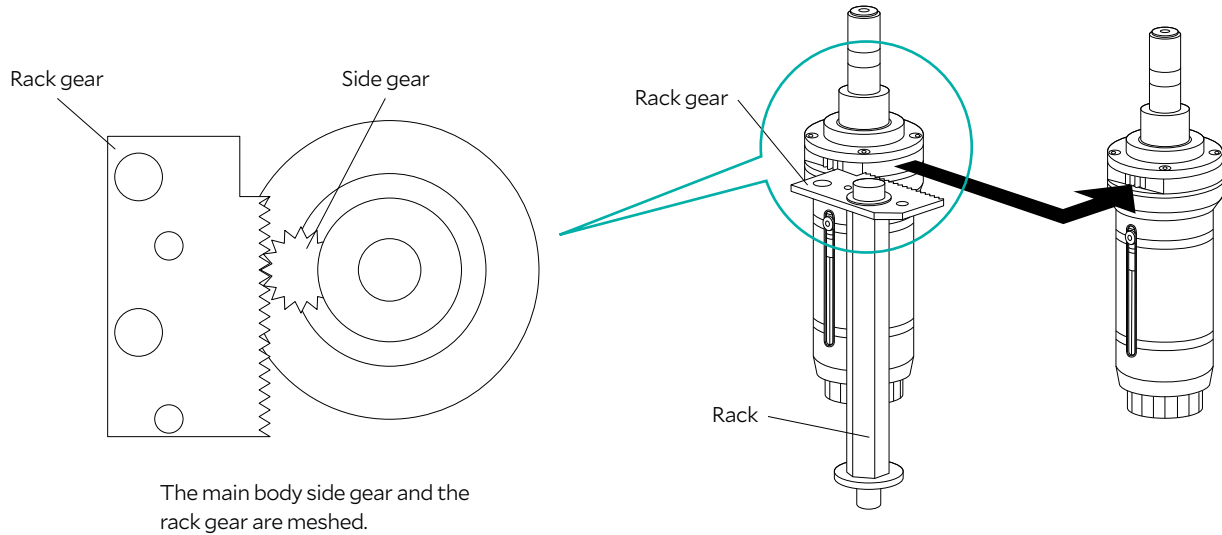

Fig. 15

## How to use

Mount the rack gear inside the machine.

The brush protrusion length is adjusted by rotating the side gear built inside the sleeve with the rack gear.



## Brush protrusion length

The brush protrusion length can be adjusted in increments of 0.05 mm.

It is possible to make an adjustment of up to 1 mm in a single pass. This allows adjustments to be made at a predetermined interval corresponding to tool wear.



MANUAL

## XEBEC Short BT Holder™

Compact tool holder whose length under the gauge line is 23.5 mm (including bush flange thickness 1.5 mm). Optimal when space is limited.

Used with  
 XEBEC Brush Surface  
 XEBEC Self-Adjusting Sleeve  
 XEBEC Floating Holder

■ Only for use with XEBEC tools



### Applicable equipment

This tool can be used with machine tools that are compatible with BT30 shanks.

### Tool outline

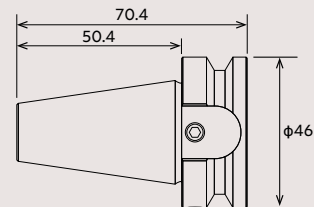

## XEBEC Brush Length Adjustment Tool™

A tool for quick in-machine brush length adjustment.

Used with  
 XEBEC Brush Surface (φ15 – 100)

Product code	Matching brush diameter (mm)	Built-in hexagonal wrench size (mm)
XP-EZ-001	φ15 / φ25 / φ40 / φ60 / φ100	1.5, 2.0

### How to use

- Move the brush rest using the adjustment knob to set the amount of brush protrusion.
- Tighten the fixing nut.
- Hold the unit in one hand and align the sleeve rest with the sleeve end.
- Loosen the adjustment screw on the sleeve to allow the bristles to drop to the brush rest.
- Tighten the adjustment screw to secure the brush in place.

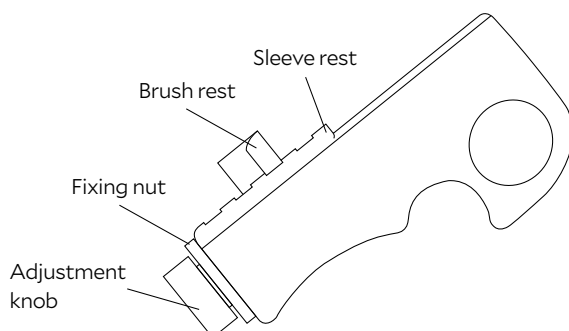

# MEMO



Special deburring cutter and made-to-order tool path

## XEBEC Back Burr Cutter and Deburring Tool Path™

“There must be a way to automate crosshole deburring!”

Our efforts to automate deburring made us aware of other problems requiring innovative solutions. We started developing a means to remove somewhat larger burrs from the edges of complex shaped workpieces, without scratching adjacent surfaces. The result was a product that combines optimal tool geometry for deburring with tool paths that inhibit burr formation. It was also symbolic of our approach to development—drawing from whatever field necessary to solve a problem.

A solution combining a made-to-order tool path program with a dedicated cutting tool for high quality finish, extended tool life and the world's fastest automated deburring of drill holes. The ready-to-use CNC program is easy to install and greatly reduces programming time.

**XEBEC Back Burr Cutter**

This cutter is made of micro-grain cemented carbide for longer life. It is heat-resistant with a AlTiCrN coating and can be used with a wide range of materials including non-ferrous metals, such as aluminum alloy, and heat-sensitive materials such as titanium. Cutting performance is improved through optimal blade geometry that inhibits formation of secondary burrs.



**XEBEC Deburring Tool Path**

Made-to-order CNC tool path program

```

03_020_EdgeBreakAmount - Notepad
File Edit Format View Help
Y INNER-1010. -205. -T2.8-ARGO. -E0)
(EDGE BREAK AMOUNT 0.20)
(UPPER EDGE)
( INC)
(DOWN CUT)

X0.000Y0.000Z0.000
X0.000Y0.000Z-2.741
X0.000Y1.338Z0.000
X-0.274Y-0.021Z0.013
X-0.262Y-0.061Z0.037
X-0.242Y-0.097Z0.054
X-0.214Y-0.127Z0.064
    
```

**High quality**

An optimized tool path and use of the ideal approach angle enables uniform break width on edges, while inhibiting formation of secondary burrs.

Before



After



Five different tool paths provide a choice of edge break widths. (Refer to p. 29 for cutter diameters and corresponding edge break widths.)

**Long tool life**

Tool life is increased by continuous displacement of the cutter contact point.

Area of tool used (contact range)

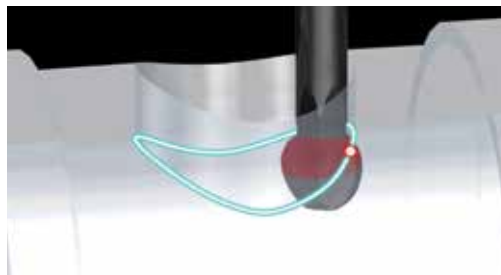

**World's fastest deburring**

Cycle time is reduced because there is no wasted motion in the cutter path. Cycle time is up 10 times faster than conventional deburring tools.

**Deburring tool comparison**

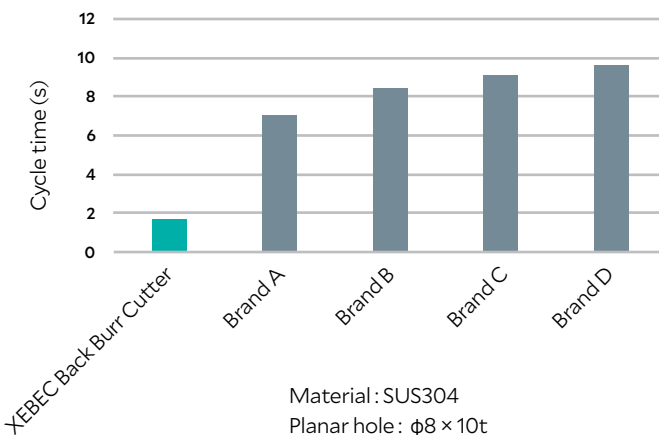

# XEBEC Back Burr Cutter™

Ideal for deburring both front and back of drilled holes.



VIDEO

## Applicable burr size

Burr thickness ≤ 0.2 mm  
(Burrs this size can be bent by fingernails)

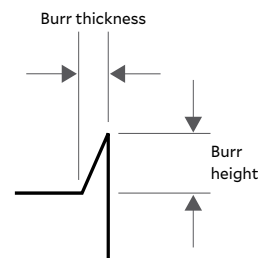

## Applicable equipment

This tool is used on equipment with 3-axis simultaneous control.



Machining center



Lathe (with live tools)

## Tool composition

Consists of a spherical deburring cutter and made-to-order tool path. Refer to p. 29 - 30 for information on the made-to-order tool path (CNC machining program).

## AlTiCrN coated

P: Steel

M: Stainless steel

K: Cast iron

S: Heat-resistant super alloy

N: Non-ferrous metal

Type	Product code	Cutter dia. Dc (mm)	Cutter rad. R (mm)	Neck dia. dn (mm)	Neck length L2 (mm)	Overall length L1 (mm)	Shank dia. Ds (mm)	Number of blades	Fig.
Short	XC-08-AS-3F	φ0.8	0.40	φ0.48	3.0	60	φ3.0	3	16
	XC-13-AS-3F	φ1.3	0.65	φ0.78	5.0	60	φ3.0	3	16
	XC-18-AS-3F	φ1.8	0.90	φ1.10	6.0	60	φ3.0	3	16
	XC-23-AS-3F	φ2.3	1.15	φ1.40	7.5	70	φ3.0	3	16
	XC-28-AS-3F	φ2.8	1.40	φ1.70	9.0	70	φ4.0	3	16
	XC-33-AS-3F	φ3.3	1.65	φ2.00	10.5	70	φ4.0	3	16
	XC-38-AS-3F	φ3.8	1.90	φ2.40	12.0	70	φ4.0	3	16
	XC-48-AS-3F	φ4.8	2.40	φ3.00	15.0	70	φ6.0	3	16
	XC-58-AS-3F	φ5.8	2.90	φ3.50	18.0	70	φ6.0	3	16
XC-78-AS-3F	φ7.8	3.90	φ4.70	24.0	100	φ8.0	3	16	
XC-98-AS-3F	φ9.8	4.90	φ5.90	30.0	120	φ10.0	3	16	
Regular	XC-08-A	φ0.8	0.40	φ0.48	5.0	60	φ3.0	2	16
	XC-13-A	φ1.3	0.65	φ0.78	8.0	60	φ3.0	2	16
	XC-18-A	φ1.8	0.90	φ1.10	10.0	60	φ3.0	2	16
	XC-23-A	φ2.3	1.15	φ1.40	12.5	70	φ3.0	2	16
	XC-28-A	φ2.8	1.40	φ1.70	15.0	70	φ4.0	2	16
	XC-33-A	φ3.3	1.65	φ2.00	17.5	70	φ4.0	2	16
	XC-38-A	φ3.8	1.90	φ2.40	20.0	70	φ4.0	2	16
	XC-48-A	φ4.8	2.40	φ3.00	25.0	70	φ6.0	2	16
	XC-58-A	φ5.8	2.90	φ3.50	30.0	70	φ6.0	2	16
XC-78-A	φ7.8	3.90	φ4.70	40.0	100	φ8.0	3	16	
XC-98-A	φ9.8	4.90	φ5.90	50.0	120	φ10.0	3	16	
Straight	XC-18-B	φ1.8	0.90	φ1.10	—	50	φ1.1	2	17
	XC-23-B	φ2.3	1.15	φ1.40	—	60	φ1.4	2	17
	XC-28-B	φ2.8	1.40	φ1.70	—	70	φ1.7	2	17
	XC-33-B	φ3.3	1.65	φ2.00	—	80	φ2.0	2	17
	XC-38-B	φ3.8	1.90	φ2.40	—	85	φ2.4	2	17
	XC-48-B	φ4.8	2.40	φ3.00	—	105	φ3.0	2	17
	XC-58-B	φ5.8	2.90	φ3.50	—	120	φ3.5	2	17
	XC-78-B	φ7.8	3.90	φ4.70	—	150	φ4.7	3	17
XC-98-B	φ9.8	4.90	φ5.90	—	180	φ5.9	3	17	

## Uncoated

N: Non-ferrous metal

O: Resin

Type	Product code	Cutter dia. Dc (mm)	Cutter rad. R (mm)	Neck dia. dn (mm)	Neck length L2 (mm)	Overall length L1 (mm)	Shank dia. Ds (mm)	Number of blades	Fig.
Regular	XC-08-A-N	φ0.8	0.40	φ0.48	5.0	60	φ3	2	16
	XC-13-A-N	φ1.3	0.65	φ0.78	8.0	60	φ3	2	16
	XC-18-A-N	φ1.8	0.90	φ1.10	10.0	60	φ3	2	16
	XC-23-A-N	φ2.3	1.15	φ1.40	12.5	70	φ3	2	16
	XC-28-A-N	φ2.8	1.40	φ1.70	15.0	70	φ4	2	16
	XC-33-A-N	φ3.3	1.65	φ2.00	17.5	70	φ4	2	16
	XC-38-A-N	φ3.8	1.90	φ2.40	20.0	70	φ4	2	16
	XC-48-A-N	φ4.8	2.40	φ3.00	25.0	70	φ6	2	16
	XC-58-A-N	φ5.8	2.90	φ3.50	30.0	70	φ6	2	16
XC-78-A-N	φ7.8	3.90	φ4.70	40.0	100	φ8	3	16	
XC-98-A-N	φ9.8	4.90	φ5.90	50.0	120	φ10	3	16	



## Applications

### Automation of deburring

#### Valve



Material: Free cutting steel  
Follows: Drilling  
Tool: XC-18-A

#### Before

Deburring was done in 3 steps ( $\phi 2$  zero cut, nylon brush deburring,  $\phi 3$  zero cut), with a different tool for each. This resulted in a long cycle time.

#### After

Deburring is performed with a single cutter. Cycle time is 9 seconds shorter and tool cost is reduced.

### Automation of deburring

#### Industrial robot part



Material: SUS304  
Follows: Tapping  
Tool: XC-18-A

#### Before

A lengthy manual deburring was followed by a tap zero cut and air blow. This resulted in a very long cycle time.

#### After

XEBEC deburring tool path reduces the deburring time from 120 to 40 seconds. The workplace is safer as manual deburring is no longer used.

## Starting parameters

AlTiCrN coated

P: Steel

M: Stainless steel

K: Cast iron

S: Heat-resistant super alloy

N: Non-ferrous metal

Type	Product code	Cutter dia. Dc (mm)	Tool protrusion length (mm)	Number of blades	Steel, SS, cast iron, HRSA		Non-ferrous metal	
					Rotational speed n (min <sup>-1</sup> )	Feed rate Vf (mm/min)	Rotational speed n (min <sup>-1</sup> )	Feed rate Vf (mm/min)
Short	XC-08-AS-3F	$\phi 0.8$	3Dc	3	20000	1080	20000	1170
	XC-13-AS-3F	$\phi 1.3$	3Dc	3	20000	1080	20000	1170
	XC-18-AS-3F	$\phi 1.8$	3Dc	3	20000	1080	20000	1170
	XC-23-AS-3F	$\phi 2.3$	3Dc	3	15000	1350	18000	1710
	XC-28-AS-3F	$\phi 2.8$	3Dc	3	12500	1800	15000	2520
	XC-33-AS-3F	$\phi 3.3$	3Dc	3	10600	1890	12700	2250
	XC-38-AS-3F	$\phi 3.8$	3Dc	3	9200	2160	11000	2880
	XC-48-AS-3F	$\phi 4.8$	3Dc	3	7200	1980	8500	2880
	XC-58-AS-3F	$\phi 5.8$	3Dc	3	6000	1620	7000	2160
Regular	XC-78-AS-3F	$\phi 7.8$	3Dc	3	4500	1620	5400	1920
	XC-98-AS-3F	$\phi 9.8$	3Dc	3	3600	1320	4300	1560
	XC-08-A	$\phi 0.8$	5Dc	2	20000	600	20000	650
	XC-13-A	$\phi 1.3$	5Dc	2	20000	600	20000	650
	XC-18-A	$\phi 1.8$	5Dc	2	20000	600	20000	650
	XC-23-A	$\phi 2.3$	5Dc	2	15000	750	18000	950
	XC-28-A	$\phi 2.8$	5Dc	2	12500	1000	15000	1400
	XC-33-A	$\phi 3.3$	5Dc	2	10600	1050	12700	1250
	XC-38-A	$\phi 3.8$	5Dc	2	9200	1200	11000	1600
Straight	XC-48-A	$\phi 4.8$	5Dc	2	7200	1100	8500	1600
	XC-58-A	$\phi 5.8$	5Dc	2	6000	900	7000	1200
	XC-78-A	$\phi 7.8$	5Dc	3	4500	1350	5400	1600
	XC-98-A	$\phi 9.8$	5Dc	3	3600	1100	4300	1300
	XC-18-B	$\phi 1.8$	10Dc	2	4400	220	4400	220
	XC-23-B	$\phi 2.3$	10Dc	2	3500	220	3500	220
	XC-28-B	$\phi 2.8$	10Dc	2	2800	220	2800	220
	XC-33-B	$\phi 3.3$	10Dc	2	2400	190	2400	190
	XC-38-B	$\phi 3.8$	10Dc	2	2000	160	2000	160
	XC-48-B	$\phi 4.8$	10Dc	2	1600	120	1600	120
	XC-58-B	$\phi 5.8$	10Dc	2	1300	100	1300	100
	XC-78-B	$\phi 7.8$	10Dc	3	650	70	650	70
	XC-98-B	$\phi 9.8$	10Dc	3	500	50	500	50

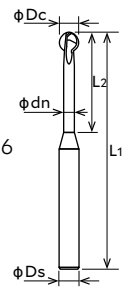

Fig. 16

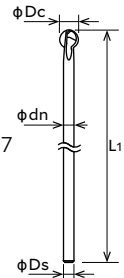

Fig. 17

### Precautions for use

- XEBEC Back Burr Cutter is designed for CNC machines. Never use it as a hand tool.
- Turning on advanced preview control on the machine tool results in uniform edges.
- The machining error on holes must be kept as small as possible.



MANUAL

Uncoated

N: Non-ferrous metal

O: Resin

Type	Product code	Cutter dia. Dc (mm)	Tool protrusion length (mm)	Number of blades	Rotational speed n (min <sup>-1</sup> )	Feed rate Vf (mm/min)
Regular	XC-08-A-N	$\phi 0.8$	5Dc	2	20000	650
	XC-13-A-N	$\phi 1.3$	5Dc	2	20000	650
	XC-18-A-N	$\phi 1.8$	5Dc	2	20000	650
	XC-23-A-N	$\phi 2.3$	5Dc	2	18000	950
	XC-28-A-N	$\phi 2.8$	5Dc	2	15000	1400
	XC-33-A-N	$\phi 3.3$	5Dc	2	12700	1250
	XC-38-A-N	$\phi 3.8$	5Dc	2	11000	1600
	XC-48-A-N	$\phi 4.8$	5Dc	2	8500	1600
	XC-58-A-N	$\phi 5.8$	5Dc	2	7000	1200
	XC-78-A-N	$\phi 7.8$	5Dc	3	5400	1600
	XC-98-A-N	$\phi 9.8$	5Dc	3	4300	1300

### Parameter adjustments

- Machining parameters will vary for the straight type when protrusion lengths other than 10D (shown in table) are used.
- Rotational speed and feed rates shown are intended as guides for setting starting parameters.
- In the event of abnormal vibration or noise, reduce the rotational speed and feed rate proportionally.
- If the maximum rotational speed and feed of the machine is below the starting parameters, reduce them both proportionally to the machine's capability.

# XEBEC Deburring Tool Path™ Patented

An integral component of this deburring solution, XEBEC Deburring Tool Path is a made-to-order CNC tool path program that ensures optimal performance of the XEBEC Back Burr Cutter.

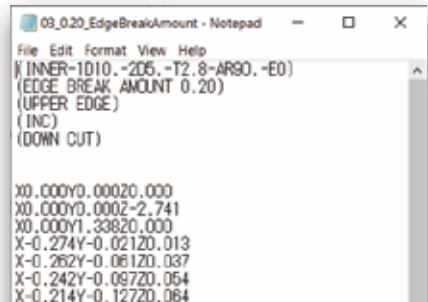

## Standard paths

Standard paths are readily available for the commonly encountered crosshole configurations shown below.

The same cutter can be used for many different types and sizes of hole. This reduces the number of tools in the ATC and the cycle time.

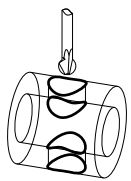

Orthogonal crosshole

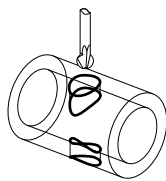

Off-center crosshole

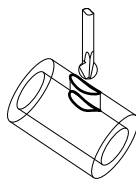

Angled crosshole

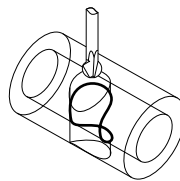

Broken crosshole

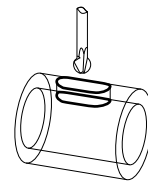

Slotted hole

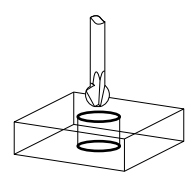

Planar hole

## Deburring amount and allowable cumulative error

Product code	Cutter dia. Dc (mm)	Edge break length (mm)					Max. allowed accumulated variance (mm)
		1	2	3	4	5	
XC-08-AS-3F/A/A-N	φ0.8	0.02	0.04	0.06	0.08	0.10	0.03
XC-13-AS-3F/A/A-N	φ1.3	0.04	0.06	0.08	0.10	0.12	0.05
XC-18-AS-3F/A/B/A-N	φ1.8	0.07	0.09	0.11	0.13	0.15	0.08
XC-23-AS-3F/A/B/A-N	φ2.3	0.07	0.09	0.11	0.13	0.15	0.09
XC-28-AS-3F/A/B/A-N	φ2.8	0.08	0.11	0.14	0.17	0.20	0.10
XC-33-AS-3F/A/B/A-N	φ3.3	0.08	0.11	0.14	0.17	0.20	0.11
XC-38-AS-3F/A/B/A-N	φ3.8	0.09	0.13	0.17	0.21	0.25	0.12
XC-48-AS-3F/A/B/A-N	φ4.8	0.10	0.15	0.20	0.25	0.30	0.15
XC-58-AS-3F/A/B/A-N	φ5.8	0.10	0.15	0.20	0.25	0.30	0.18
XC-78-AS-3F/A/B/A-N	φ7.8	0.10	0.15	0.20	0.25	0.30	0.18
XC-98-AS-3F/A/B/A-N	φ9.8	0.10	0.15	0.20	0.25	0.30	0.18

## Standard Path for Tapped Holes

Tap size	Matching cutter product code	Cutter dia. Dc (mm)	Deburring amount (mm)
M3	XC-23-AS-3F/A/B/A-N	φ2.3	0.11
M4	XC-28-AS-3F/A/B/A-N	φ2.8	0.14
M5	XC-33-AS-3F/A/B/A-N	φ3.3	0.14
M6	XC-38-AS-3F/A/B/A-N	φ3.8	0.17
M8	XC-48-AS-3F/A/B/A-N	φ4.8	0.20
M10	XC-58-AS-3F/A/B/A-N	φ5.8	0.20
M12	XC-78-AS-3F/A/B/A-N	φ7.8	0.20
M16 - 24	XC-98-AS-3F/A/B/A-N	φ9.8	0.20

Standard paths are available for thread sizes from M3 to M24.

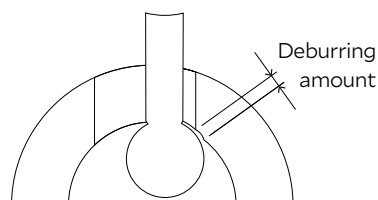

■ Deburring amount is the chamfer width after an edge is deburred.

## XEBEC Deburring Tool Path All Edges

A customized tool path for extremely complex edge profiles.

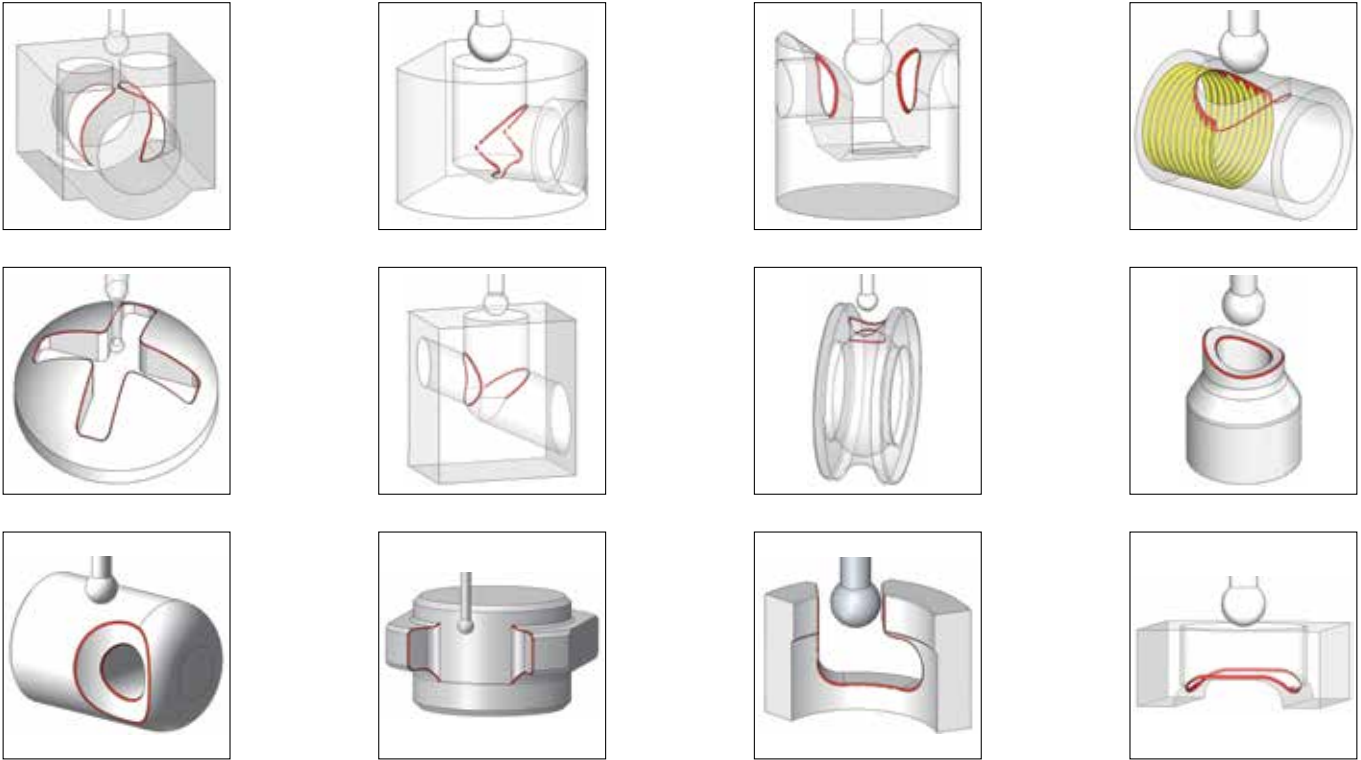

## How to order standard paths

A made-to-order tool path for commonly encountered crosshole configurations.

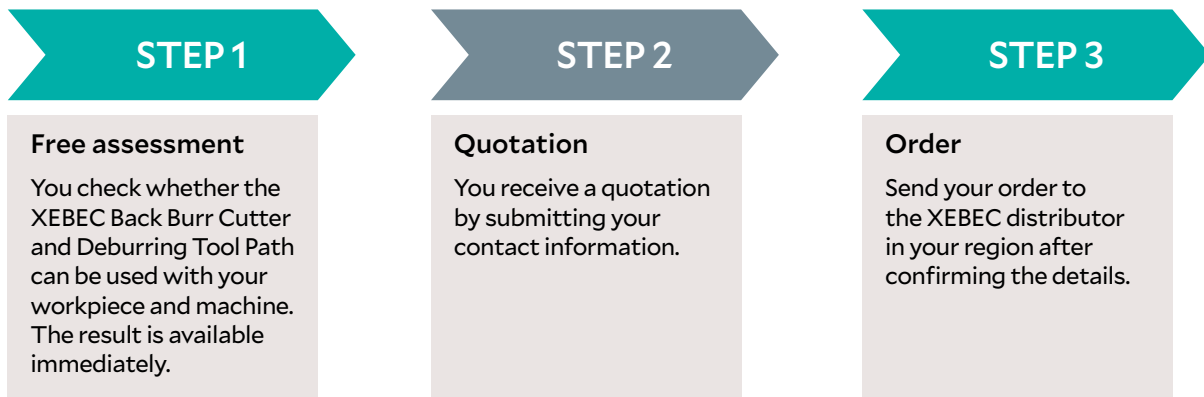

### Online Application Form

All you need to do is to enter a few dimensions including hole diameters and to specify the orientation of the workpiece inside the machine.

Visit the special website below to conduct a self-assessment and submit a request for quotation.

<https://xebec-backburr-cutter.com>



WEBSITE

### Ordering XEBEC Deburring Tool Path All Edges

Please contact XEBEC directly to request XEBEC Deburring Tool Path All Edges, a customized solution for deburring paths which do not belong to the six standard types shown on p. 29.

Burrless chamfering with the world's first V-shaped blade

## XEBEC Burrless Chamfering Cutter™

“Let’s make a chamfering tool that only XEBEC would think of.”

At the time, we were looking for additional ways to automate the deburring process and reduce the burden on users. The tools we offered could not provide an exact chamfer. In many cases, users had to alter break edge instructions on drawings to permit edge blending. After much consideration, we came up with the concept of a chamfering tool that does not produce secondary burrs. And settled on the world’s first V-shaped blades as the optimal choice for our tool.



The unique V-shaped blades eliminate the need for deburring after chamfering, reducing man-hours required for deburring, the cost of tools, and machining times.



### Reduction of deburring man-hours

The world's first V-shaped blades (patented) chamfer without creating secondary burrs, eliminating the need for deburring after chamfering.

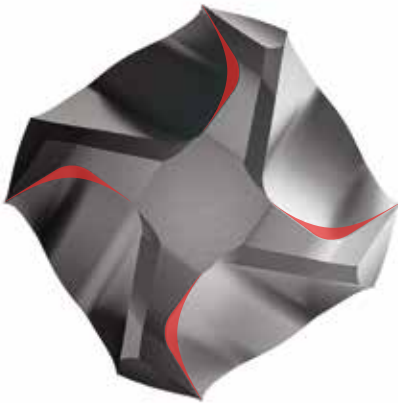

### Reduction of tool costs

This cutter has twice the tool life of conventional chamfering tools.

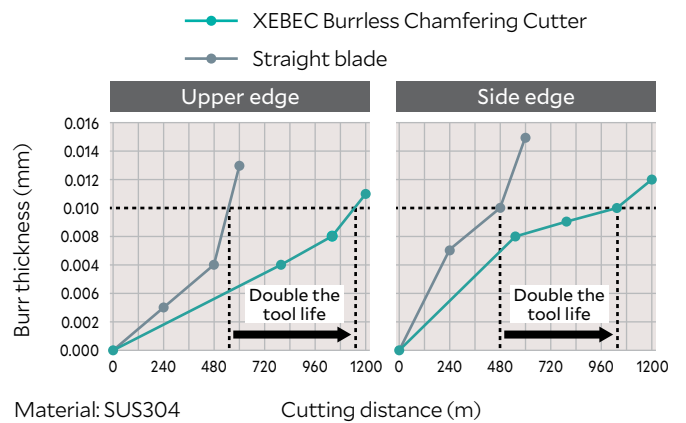

### Reduced machining times

The multi-blade design enables high feed rates for reduced machining time.



### Flat tip

Flat tool tip prevents rounding and chipping of the tool tip, reducing tool length measurement errors and improving machining positional accuracy.

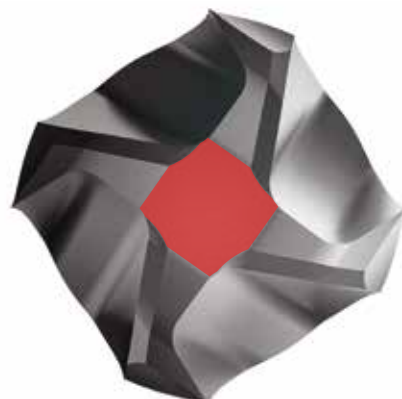

# XEBEC Burrless Chamfering Cutter™ Patented

Burrless chamfering with world's first V-shaped blade



VIDEO

## Applicable equipment

This tool can be mounted on equipment shown below.



Machining center



Lathe (with live tools)

**AlTiCrN coated** P: Steel M: Stainless steel K: Cast iron S: Heat-resistant super alloy N: Non-ferrous metal

Product code	Chamfer alignment dia. Dc (mm)	Shank diameter Dcon (mm)	Overall length LF (mm)	Neck length L1 (mm)	Maximum depth of cut APMX (mm)	Cutting angle KAPR (deg.)	Number of blades	Chamfering size (mm)	Fig.
XC-C-03-M	φ2	φ6	50	5	1	45	3	C0.3 - C0.6	18
XC-C-06-M	φ4	φ6	60	—	2	45	4	C0.7 - C1.5	19

**Uncoated** N: Non-ferrous metal O: Resin

Product code	Chamfer alignment dia. Dc (mm)	Shank diameter Dcon (mm)	Overall length LF (mm)	Neck length L1 (mm)	Maximum depth of cut APMX (mm)	Cutting angle KAPR (deg.)	Number of blades	Chamfering size (mm)	Fig.
XC-C-03-N	φ2	φ6	50	5	1	45	3	C0.3 - C0.6	18
XC-C-06-N	φ4	φ6	60	—	2	45	4	C0.7 - C1.5	19

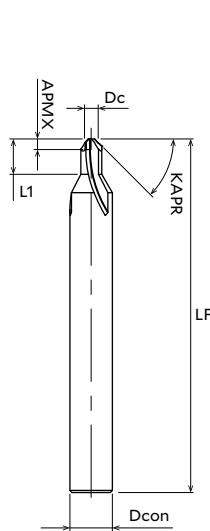

Fig. 18

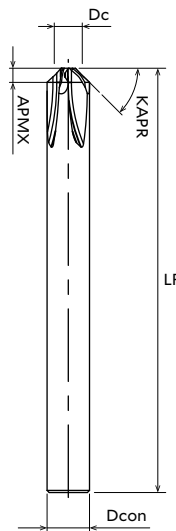
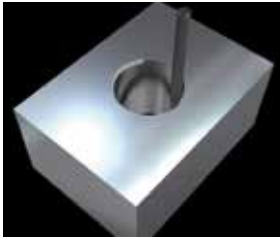

Fig. 19

## Applications

### Automation of chamfering

#### Cooling water pipe block



##### Before

Burrs were formed when chamfering. Manual deburring was required.

##### After

Shortened the chamfering time. Manual deburring is no longer required after chamfering.

Material: SUS304  
Follows: Drilling  
Tool: XC-C-06-M

### Automation of chamfering

#### Machine tool jig



##### Before

Oil stone was used to remove burrs after chamfering. However, it scarred the surface.

##### After

Oil stone is no longer needed and quality is improved.

Material: S50C  
Follows: End milling  
Tool: XC-C-06-M

## How to use

Position the chamfering alignment diameter at the chamfering center point of the workpiece.

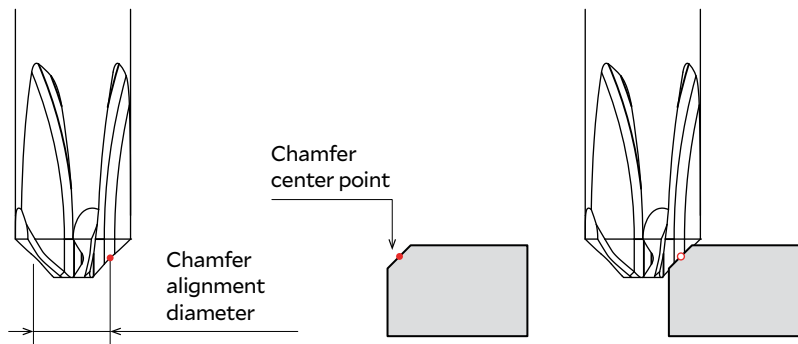

## Machining parameters

### Offsets

Product code	Chamfering size (mm)	Offsets (mm)	
		A	B
XC-C-03-M/N	C0.3	0.85	0.65
	C0.4	0.80	0.70
	C0.5	0.75	0.75
	C0.6	0.70	0.80
XC-C-06-M/N	C0.7	1.65	1.35
	C0.8	1.60	1.40
	C0.9	1.55	1.45
	C1.0	1.50	1.50
	C1.1	1.45	1.55
	C1.2	1.40	1.60
	C1.3	1.35	1.65
	C1.4	1.30	1.70
	C1.5	1.25	1.75

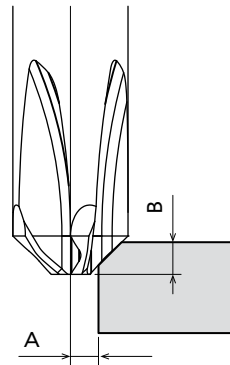

### Starting parameters

Product code	Workpiece material	Cutting speed (m/min)	Rotational speed (min <sup>-1</sup> )	Feed rate (mm/min)	Feed per tooth (mm/t)
XC-C-03-M	Steel	60 - 100	12000	1800	0.05
	Stainless steel	40 - 80	9000	1350	0.05
	64 titanium	45 - 60	8000	1200	0.05
	Inconel	20 - 30	4000	600	0.05
XC-C-03-N	Aluminum alloy	200 - 300	40000	6000	0.05
	Resin	60 - 100	12000	1800	0.05
XC-C-06-M	Steel	60 - 100	6300	1260	0.05
	Stainless steel	40 - 80	4800	960	0.05
	64 titanium	45 - 60	4000	800	0.05
	Inconel	20 - 30	2000	400	0.05
XC-C-06-N	Aluminum alloy	200 - 300	20000	4000	0.05
	Resin	60 - 100	6300	1760	0.07



MANUAL

XEBEC Ceramic Stone™





## XEBEC Ceramic Stone™

“A friend with a dream worth realizing.”

XEBEC was founded from a belief in the invention of a childhood friend. A grindstone that can be molded, but does not bend, break, or chip. With the vision of the world’s best ceramic grindstone firmly in their minds, two friends teamed up with a materials manufacturer and developed a unique ceramic fiber suited to grinding. They also received a patent for a grindstone with an original structure that maximizes strength and polishing performance. Known as XEBEC Ceramic Stone, this product now dominates the market for the polishing of intricate features in molds, such as ribs, bosses and corners, and has a reputation for making manual deburring safer and more efficient.

# XEBEC Stone™ Flexible Shaft Patented

Deburring and polishing front and back of crossholes, grooves and areas deep inside the workpiece. The spring steel shaft absorbs vibrations for a soft surface contact.

## Applicable burr size

Burr thickness ≤ 0.2 mm  
(Burrs this size can be bent by fingernails)

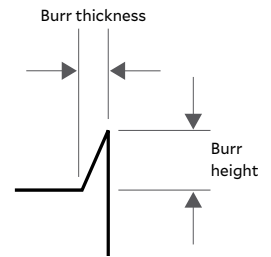

VIDEO



## Applicable equipment

This tool is used on equipment with rotational speed control.



Machining center



Lathe (with live tools)



Dedicated machine



Robot



Rotary tool (electric)

## Ball type

Equivalent grit (color)	Product code	Head size (mm)	Shaft dia. (mm)	Shank dia. (mm)	Overall length L (mm)	Standard rotational speed (min <sup>-1</sup> )	Maximum rotational speed (min <sup>-1</sup> )	Fig.
#800 (blue)	CH-PB-3B	φ3	φ1.5	φ3.0	70	5000 - 8000	15000	20
	CH-PB-4B	φ4	φ1.5	φ3.0	70	5000 - 8000	13000	20
	CH-PB-5B	φ5	φ1.5	φ3.0	70	5000 - 8000	12000	20
	CH-PB-6B	φ6	φ1.5	φ3.0	70	5000 - 8000	10000	20
#400 (orange)	CH-PO-3B	φ3	φ1.5	φ3.0	70	5000 - 8000	15000	20
	CH-PO-4B	φ4	φ1.5	φ3.0	70	5000 - 8000	13000	20
	CH-PO-5B	φ5	φ1.5	φ3.0	70	5000 - 8000	12000	20
	CH-PO-6B	φ6	φ1.5	φ3.0	70	5000 - 8000	10000	20
#220 (gray)	CH-PM-3B	φ3	φ1.5	φ3.0	70	5000 - 8000	15000	20
	CH-PM-4B	φ4	φ1.5	φ3.0	70	5000 - 8000	13000	20
	CH-PM-5B	φ5	φ1.5	φ3.0	70	5000 - 8000	12000	20
	CH-PM-6B	φ6	φ1.5	φ3.0	70	5000 - 8000	10000	20
	CH-PM-10B	φ10	φ1.5	φ3.0	70	4000 - 5000	6000	20
	CH-PM-3B-L	φ3	φ1.5	φ3.0	150	—	1000	20
	CH-PM-4B-L	φ4	φ2.3	φ2.3	150	—	3000	21
	CH-PM-5B-L	φ5	φ2.3	φ2.3	150	—	3000	21
	CH-PM-6B-L	φ6	φ2.3	φ2.3	150	—	3000	21
	CH-PM-10B-L	φ10	φ2.3	φ2.3	150	—	2000	21

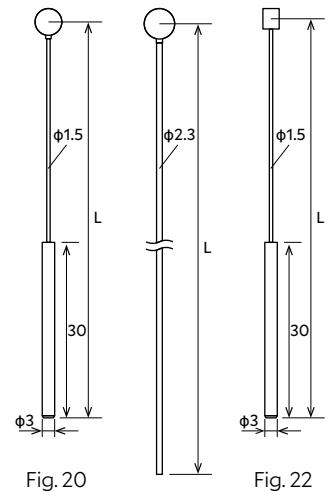

Fig. 20

Fig. 21

Fig. 22

CH-PM-4B-L  
CH-PM-5B-L  
CH-PM-6B-L  
CH-PM-10B-L

## Cylinder type

Equivalent grit (color)	Product code	Head size (mm)	Shaft dia. (mm)	Shank dia. (mm)	Overall length L (mm)	Standard rotational speed (min <sup>-1</sup> )	Maximum rotational speed (min <sup>-1</sup> )	Fig.
#800 (blue)	CH-PB-3R	φ3 × 3	φ1.5	φ3	70	5000 - 8000	15000	22
	CH-PB-4R	φ4 × 4	φ1.5	φ3	70	5000 - 8000	13000	22
	CH-PB-5R	φ5 × 5	φ1.5	φ3	70	5000 - 8000	12000	22
#400 (orange)	CH-PO-3R	φ3 × 3	φ1.5	φ3	70	5000 - 8000	15000	22
	CH-PO-4R	φ4 × 4	φ1.5	φ3	70	5000 - 8000	13000	22
	CH-PO-5R	φ5 × 5	φ1.5	φ3	70	5000 - 8000	12000	22
#220 (gray)	CH-PM-3R	φ3 × 3	φ1.5	φ3	70	5000 - 8000	15000	22
	CH-PM-4R	φ4 × 4	φ1.5	φ3	70	5000 - 8000	13000	22
	CH-PM-5R	φ5 × 5	φ1.5	φ3	70	5000 - 8000	12000	22
	CH-PM-5R-C01	φ5 × 10	φ1.5	φ3	70	5000 - 8000	12000	22

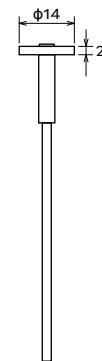

Fig. 23

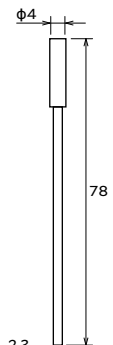

Fig. 24

## Disc type - stone

Equivalent grit (color)	Product code	Head dia. x thickness (mm)	Max. rotational speed (min <sup>-1</sup> )	Fig.
#220 (gray)	CH-PM-14D	φ14 × 2	5000	23

## Disc type - shaft

Product code	Shaft dia. (mm)	Overall length (mm)	Mounting screw	Max. rotational speed (min <sup>-1</sup> )	Fig.
CH-D-SH	φ2.3	78	M2 × 6	5000	24

## Applications

Deburring crosshole

### Aircraft pipe part



Material: Stainless steel  
Follows: Drilling  
Tool: CH-PM-6B

#### Before

Deburring was carried out with a rubber grinding stone on a rotary tool. Finish quality varied depending on the workers' skill. 40 minutes was required to deburr 16 crossholes.

#### After

The tool is inserted in a crosshole and retracted gently while tracing around the hole edge. Quality of finish is uniform and less time is required for deburring.

Deburring groove hole

### Shaft



Material: SCM  
Follows: Drilling  
Tool: CH-PM-145D

#### Before

An oil-impregnated grinding disc was used. The grinding stone shaft was short, making it difficult to access the deburring area. Tool life was poor.

#### After

The longer shaft of the disc type grinding stone makes it easy to access the groove. The ceramic fiber stone is replaced less often because it has a longer tool life. The shaft is reusable. Only the grinding stone is replaced.

## How to use

The entire surface of the ceramic stone is abrasive and therefore can be used for deburring and polishing.

### Ball type



### Cylinder type



### Disc type



## Characteristics

The spring steel shaft absorbs vibrations for soft contact with the workpiece surface. The ceramic stone does not bounce around, thereby reducing the risk of scratching the workpiece. This makes this tool ideal for polishing and deburring areas that are deep inside the workpiece. The stone is safe to touch as it is not a cutting tool.

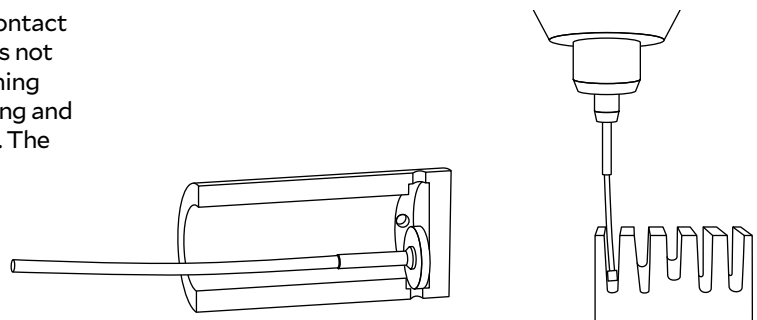

### Trial set

This set includes a disc type stone and shaft.

Product code
CHPM14D-SET

### φ2.3 to φ3 Collet Adapter

Adapts the φ2.3 shaft to fit on rotary tools with φ3 shanks.

Product code
RMP3024X

### Precautions for use

A ceramic stone tool will be damaged when:

- used beyond the maximum rotation speed
- used with a pneumatic rotary tool

Users of the disc type should be careful to use only normal (clockwise) rotation. Reverse (counter-clockwise) rotation may cause the screw to loosen and the head to fly off.



MANUAL

# XEBEC Stone™ Mounted Point

Suitable for use with pneumatic rotary tools at high rotational speed

**Applicable burr size**  
 Burr thickness ≤ 0.2 mm  
 (Burs this size can be bent by fingernails)

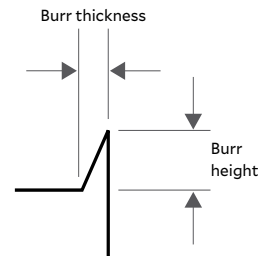

VIDEO



## Applicable equipment

This tool can be mounted on rotary tools.



Rotary tool  
(electric)



Rotary tool  
(pneumatic)

Equivalent grit (color)	Product code	Head size (mm)	Shank dia. (mm)	Head length (mm)	Overall length (mm)	Maximum rotational speed (min <sup>-1</sup> )	Fig.
#220 (gray)	AX-PM-3R	φ3	φ3	20	48	60000	25
	AX-PM-5RF	φ5	φ3	8	48	30000	26
	AX-PM-6T	φ6	φ3	20	48	60000	27

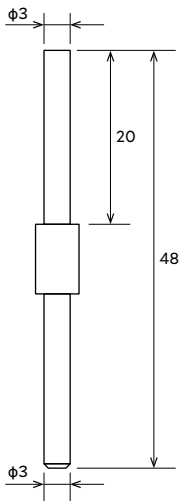

Fig. 25  
AX-PM-3R

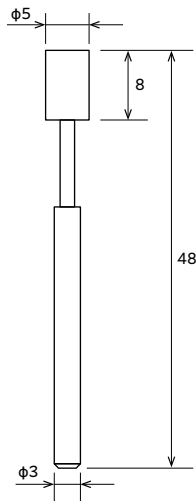

Fig. 26  
AX-PM-5RF

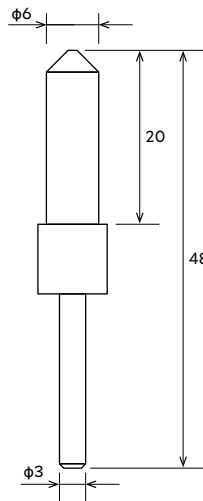

Fig. 27  
AX-PM-6T

## Applications

### Deburring of edges



#### Before

A file was used for deburring. However, it caused secondary burrs and a quality problem.

#### After

Secondary burrs are not formed and edge quality is improved.

Material: Stainless steel  
Tool: AX-PM-6T

### Deburring of parting lines



#### Before

A rotary bar was used because the burrs were large. However, there was a safety problem.

#### After

The switch to abrasive stone makes the process safer to perform. The ceramic fiber stone's grinding power improves work efficiency.

Material: Aluminum  
Tool: AX-PM-6T

## How to use

All surfaces of the ceramic stone are abrasive and all of them can be used for deburring and polishing. These ceramic stones are capable of withstanding high speed. As such they can be used with pneumatic rotary tools in addition to electric rotary tools.



MANUAL

# Mobile Micromotor System

Battery-powered rotary tool for use at workstations where power supply is unavailable. The handpiece is ultra-lightweight, ideal for manual operation without causing fatigue.



Product code	Matching shank diameter (mm)	Maximum rotational speed (min <sup>-1</sup> )	Standard components
M2P33STX	φ3 mm shank	30000	Handpiece with stand, controller, ON/OFF foot switch, power cable for charging

■ Capable of about 5 hours of continuous use on a single charge.



# XEBEC Brush™ Surface

## How to select

Refer to the charts below and select the brush color based on the workpiece material, burr thickness and surface roughness.

### Deburring

Workpiece material	Resin	Copper, Brass		
		Aluminum		
		Steel		
			Stainless steel	
			HRSA steel	
			Cast iron	
			Hard material	
Burr size	Micro fine burrs			
	Burr thickness ( $\leq 0.1\text{mm}$ )			
	Burr thickness ( $0.1 - 0.2\text{mm}$ )			
Brush (color)	A13 (pink)	A11 (red)	A21 (white)	A32 (blue)
Grinding power	→ High			

- Not all brush colors are available in all sizes.
- HRSA (heat resistant super alloy)

### Cutter mark removal and polishing

Workpiece material	Copper, Brass			
	Aluminum			
	Steel			
			Stainless steel	
			HRSA steel	
		Cast iron		
		Hard material		
Achievable surface roughness	$\leq Ra\ 0.1\ \mu\text{m}$		$\geq Ra\ 0.1\ \mu\text{m}$	
Brush (color)	A13 (pink)	A11 (red)	A21 (white)	A32 (blue)
Grinding power	→ High			

- Not all brush colors are available in all sizes.
- HRSA (heat resistant super alloy)

## Machining adjustments - Burrs remain

Take the following actions, if burrs remain despite using the recommended depth of cut for the given burr size.

### 1. Increase rotational speed

Increase the rotational speed to the maximum.

Brush size (mm)	Product code	Initial rotational speed (min <sup>-1</sup> )	Maximum rotational speed (min <sup>-1</sup> )
φ6	A13-CB06M, A11-CB06M, A21-CB06M, A32-CB06M	8000	10000
φ15	A13-CB15M, A11-CB15M, A21-CB15M, A32-CB15M	4800	6000
φ25	A11-CB25M, A21-CB25M, A32-CB25M	4000	5000
φ40	A11-CB40M, A21-CB40M, A32-CB40M	2400	3000
φ60	A11-CB60M, A21-CB60M, A32-CB60M	1600	2000
φ100	A11-CB100M, A21-CB100M, A32-CB100M	960	1200
φ125	A11-CB125M, A21-CB125M, A32-CB125M	800	1000
φ165	A11-CB165M, A21-CB165M, A32-CB165M	600	750
φ200	A11-CB200M, A21-CB200M, A32-CB200M	480	600

### 2. Check the rotational direction of the brush

XEBEC recommends cutting upwards so that the bristles lift burrs up.

### 3. Change the brush color

Check whether the brush color is suitable for the workpiece material and burr size. The grinding power of colors increases as follows: pink < red < white < blue.



## Machining adjustments - Edges too rounded

It is not possible to remove burrs with brushes without rounding edges to some extent. Take the following actions to improve edge sharpness.

### 1. Increase feed rate

To make a sharper edge, increase the feed rate in 1,000 mm/min increments within the range where burrs can be removed. Increasing the feed rate also helps reduce the cycle time.

### 2. Decrease rotational speed

Decrease rotational speed in 10 to 20 percent increments within the range where burrs can be removed.

### 3. Check the brush color

Check whether the brush color is suitable for the workpiece material and burr size. Rounding of edges increases as follows: pink < red < white < blue.

## Reference data - Tool life

### Example 1

Material	Aluminum die-casting
Follows	Face milling
Burr thickness	0.1 mm
Tool path length	1000 mm/piece

Tool	A11-CB25M
Rotational speed	4000 min <sup>-1</sup>
Feed rate	2400 mm/min
Depth of cut	1 mm
Wear amount	50 mm out of 75 mm

Tool life	10 km (10000 pieces)
-----------	----------------------

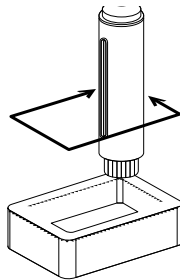

### Example 2

Material	S45C
Follows	End milling
Burr thickness	0.1 mm
Tool path length	200 mm/piece

Tool	A21-CB25M
Rotational speed	4000 min <sup>-1</sup>
Feed rate	2000 mm/min
Depth of cut	0.5 mm
Wear amount	50 mm out of 75 mm

Tool life	3 km (15000 pieces)
-----------	---------------------

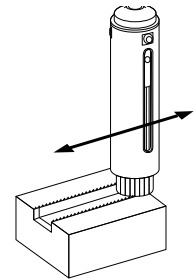

- Tool life varies greatly depending on the material, machining conditions, and burr size and direction.
- The above data is not guaranteed. Please use as a guide.

## Machining adjustments - Surface roughness worsens

It may be possible to improve the surface finish. Try the following.

### 1. Check the brush color

The ability to improve surface roughness is inversely proportional to the grinding power, meaning that A13 (pink) achieves the best surface roughness, followed by A11 (red), A21 (white), and A32 (blue). Make sure to select the appropriate brush color based on the workpiece material and target surface roughness.

### 2. Wet machining

The brush can be used for both dry and wet (oil-based and water-soluble) machining. Wet machining may improve surface roughness and tool life.

### 3. Increase the number of passes

When comparing with the same cycle time, increasing the number of passes makes a bigger difference than decreasing the feed rate.

### Example

Rotational speed	4000 min <sup>-1</sup>
Depth of cut	0.5 mm
Feed rate	600 mm/min
Number of passes	1



Rotational speed	4000 min <sup>-1</sup>
Depth of cut	0.5 mm
Feed rate	1200 mm/min
Number of passes	2





## Reference data - Surface roughness after deburring

Material	A11 (red)	A21 (white)	A32 (blue)
A5052	Approx. Ra 0.6 μm, Rz 5.0 μm		
S50C		Approx. Ra 0.2 μm, Rz 1.6 μm	
SUS304			Approx. Ra 0.3 μm, Rz 2.4 μm

# XEBEC Brush™ Surface End Type

## How to select

Refer to the chart below and select the brush color based on the workpiece material, burr thickness and surface roughness.



Workpiece material	Resin	Copper, Brass		
		Aluminum		
		Steel		
				Stainless steel
				HRSA steel
			Cast iron	
			Hard material	
Burr size	Micro fine burrs			
		Burr thickness ( $\leq 0.1\text{mm}$ )		
Achievable surface roughness	$\leq \text{Ra } 0.1 \mu\text{m}$			
		$\geq \text{Ra } 0.1 \mu\text{m}$		
Brush (color)	A13 (pink) 	A11 (red) 	A21 (white) 	A32 (blue) 
Grinding power	—————→ High			

■ HRSA (heat resistant super alloy)

# XEBEC Brush™ Crosshole

## How to select

Refer to the chart below and select the brush color based on the workpiece material, burr thickness and surface roughness.

Workpiece material	Resin	Steel
	Copper, Brass	Stainless steel
	Aluminum	
		HRSA steel
		Cast iron
	Hard material	
Burr size	Micro fine burrs	
		Burr thickness ( $\leq 0.1\text{mm}$ )
Achievable surface roughness	$\leq \text{Ra } 0.1 \mu\text{m}$	$\geq \text{Ra } 0.1 \mu\text{m}$
Brush (color)	A12 (red) 	A33 (blue)  A34 (dark blue) 
Grinding power	→ High	

■ HRSA (heat resistant super alloy)

## Machining adjustments - Burrs remain

Take the following actions, if burrs remain despite using the correct brush and rotational speed for the given burr size.

1. Check the brush color
2. Increase rotational speed to the maximum
3. Increase the number of passes
4. Decrease the feed rate

## Machining adjustments - Extending tool life

Try the following, if tool life is short despite using the correct brush for the given burr size.

1. Decrease the rotational speed
2. Increase the feed rate

### Example

Material	S45C
Follows	Drilling
Burr thickness	0.1 mm
Main bore	$\phi 10 \text{ mm}$
Crosshole	$\phi 5 \text{ mm}$

Tool	CH-A12-5M-TL
Rotational speed	$10000 \text{ min}^{-1}$
Feed rate	$300 \text{ mm/min}$
Depth of cut	1 mm
Wear amount	10 mm out of 50 mm

Tool life	4500 holes
-----------	------------

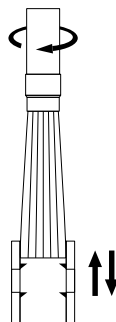

- Tool life varies greatly depending on the material, machining conditions, and burr size and direction.
- The above data is not guaranteed. Please use as a guide.

# XEBEC Brush™ Surface Wheel Type

## Machining adjustments - Burrs remain

Take the following actions, if burrs remain despite using the recommended depth of cut for the given burr size.

### Increase the feed amount

Increase the feed amount in increments of 10 to 20 percent.

## Machining adjustments - Extending tool life

Try the following, if tool life is short despite using the correct brush for the given burr size.

### Increase the feed amount

Increase the feed rate in increments of 10 to 20 percent.

## Reference data - Tool life

It is not possible to remove burrs with brushes without rounding edges to some extent. Take the following actions to improve edge sharpness.

### Example

Material	S45C
Follows	End milling
Burr thickness	0.1 mm
Tool path length	120 mm/piece

Tool	W-A11-50
Cutting speed (Rotational speed)	250 m/min (1600 min <sup>-1</sup> )
Feed per bundle (Feed rate)	0.7 mm/bundle (7000 mm/min)
Depth of cut	0.2 mm
Wear amount	50 mm out of 75 mm

Tool life	600 m (5000 pieces)
-----------	---------------------

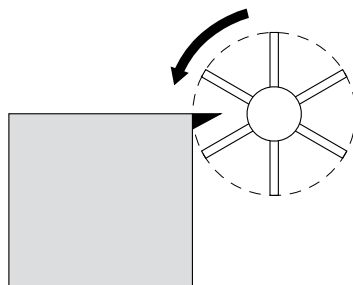

- Tool life varies greatly depending on the material, machining conditions, and burr size and direction.
- The above data is not guaranteed. Please use as a guide.

# XEBEC Floating Holder™

## Maintenance

Schedule a regular maintenance for cleaning and greasing sliding parts to ensure smooth movement and functioning. Recommended grease: Lithium soap grease (NLGI Grade #2).

## Safety Precautions

- Please make sure to **read the instruction manual before use.**
- In order to ensure safety, be sure to **observe the operator safety measures and operational precautions listed below.**

The following precautions exist to ensure safe use of the products and prevent injury to persons using the products and other persons in the vicinity, as well as prevent property damage. They are classified as “Warnings” and “Cautions” depending on the level of potential injury and danger involved. “Warnings” and “Cautions” should be strictly observed as they all are related to safety.

### [WARNINGS]

These have the potential to cause death or serious injury to persons or serious property damage if handled improperly.

### [CAUTIONS]

These have the potential to cause injury to persons or property damage if handled improperly.

## Warnings

### [Use of protective clothing and equipment]

Wear safety glasses, protective gloves and masks when using the tools. Wear clothing with long sleeves or other clothing that does not expose the skin. Cuffs and hems of clothing should be tightly fastened.

### [Use of protective covers]

Machine tools and dedicated machines should be equipped with covers and other safety measures capable of protecting users from injury in the event of tool fragmentation.

### [Cutting dust and particles]

Cutting dust and burrs are scattered into the air with the rotation of the tool. These should be removed by a dust collector and persons should not enter the affected area.

### [Work surroundings]

An enclosure should be installed around the work area to prevent persons other than the operator from entering the work area. Persons who enter the work area should always wear protective clothing and use protective equipment.

*Ignoring the aforementioned warnings may result in the following:*

- *Fragments and cutting particles may enter the eyes, causing loss of sight in severe cases.*
- *Fragments and cutting particles may cause injury by cutting into skin.*
- *Cutting dust resulting from tool use may irritate the skin, cause allergic reactions and damage lungs.*

## Cautions

### [Prior to machining]

Operate the tool for at least one minute (3 minutes after the tool has been replaced) before conducting any actual cutting. Cease operation immediately in the event of any sign of abnormality with the machine or loosening of the tool shank. Continued use may result in the shank flying out of the holder, causing damage to the machine, the jig, and workpiece, as well as injury or loss of sight to the operator.

### [Abnormal vibration]

Cease operation immediately at the first sign of abnormalities such as vibration. Continued use may result in the shank flying out of the holder, causing damage to the machine, the jig, and workpiece, as well as injury or loss of sight to the operator.

### [Maximum rotational speed]

Do not operate the tool beyond its maximum rotational speed. Set the machining conditions based on the instruction manual. Operation at speeds beyond the maximum rotational speed may damage the tool, the machine, the workpiece, and also cause loss of sight or other injury to the operator.

- *A dust collector should be used during machining and cleaned thoroughly afterwards.*
- *Insufficient removal of dust and cleaning of dust collectors may result in damage to machine tool slides and other exposed sliding surfaces.*

# About XEBEC

## Beautiful deburring

XEBEC has been helping factories and machining shops around the world automate their deburring processes since 2002. With our wealth of knowledge accumulated over the years, we strive everyday to solve customer deburring problems faster than before. We aim to change the way people think about deburring and create value-added in customers' finishing processes. A world where people can make use of their creative talents to the fullest, is a world where XEBEC wants to be.

## XEBEC's three innovations

### Technology innovation

Ongoing technological innovation through integration of materials, hardware and software from many scientific fields enables us to find superior solutions to fundamental problems.

### Process innovation

Challenging accepted practices to optimize and innovate business processes such as product marketing, manufacturing, sales and delivery.

### Precision Management

Attaching the upmost importance to every aspect of quality management, such as stable product quality, shipping accuracy, and timely and polite customer support.

## Corporate outline

Corporate name	XEBEC Technology Co., Ltd	Head office	Fuerte Kojimachi 1-7 Building 4F Kojimachi 1-7-25, Chiyoda-ku Tokyo, Japan 102-0083
Incorporated	June 3, 1996		
Main business	Development, manufacturing and sales of industrial tools for deburring, polishing, chamfering, and surface finishing.	Tel. +81-3-3239-3481 Fax. +81-3-5211-8964	
Capitalization	JPY 99,000,000		
President & CEO	Norihiko Sumiyoshi		

# History

XEBEC Burrless Chamfering Cutter™ released.	Jul. 2023	
XEBEC Stone™ Flexible Shaft Disc Type released.	Feb. 2022	
XEBEC Brush™ Crosshole Extra-Large released.	Sep. 2021	
	Nov. 2018	Corporate branding renewed.
	Jun. 2018	XEBEC Back Burr Cutter and Deburring Tool Path chosen product of the year in Germany's Best of Industry Awards (cutting division).
	Mar. 2017	'Deburring Productivity Day' certified by Japan Anniversary Association
XEBEC Brush™ Wheel Type released.	Oct. 2016	
XEBEC Back Burr Cutter and Deburring Tool Path™ released.	Jun. 2016	
	Nov. 2015	'XEBEC Plus Engineering Center' opened in Okazaki, Aichi.
XEBEC Self-Adjusting Sleeve™ released.	Oct. 2015	
Mobile Micromotor System released.	Apr. 2015	
	Mar. 2015	One of 100 companies awarded the Diversity Management Award by the Ministry of Economy, Trade and Industry.
	May 2014	Headquarters moved to current location at Kojimachi, Chiyoda-ku, Tokyo.
	Jun. 2013	'XEBEC Plus R&D Center' opened in Ota-ku, Tokyo. Vertical machining center (with additional axis) acquired.
XEBEC Brush Length Adjustment Tool™ released.	Apr. 2013	
	Aug. 2012	Test cut facility established at the head office. SCARA robot acquired.
XEBEC Floating Holder™ released.	Oct. 2010	
XEBEC Stone™ Mounted Point released.	Oct. 2008	
	Oct. 2007	Norihiko Sumiyoshi appointed president and CEO.
XEBEC Stone™ Flexible Shaft released. XEBEC Brush™ Crosshole released.	Nov. 2004	
XEBEC Brush™ Surface released.	Apr. 2002	
XEBEC Ceramic Stone™ Meister Finish released.	May 1998	
	Jun. 1997	Certified as an authorized corporation by the Ministry of Economy, Trade and Industry under the Act on Temporary Measures for Facilitating Specific New Businesses.
	Jun. 1996	XEBEC Technology Co., Ltd incorporated. (Founder: Takehiko Sumiyoshi)







Spazzole  
con abrasivo  
ceramico nero.

**CERASEF**



# Spazzole a Ruota con filamenti con abrasivo ceramico nero per sbavatura a macchina e in cella di sbavatura

## Y100

# CERASEF

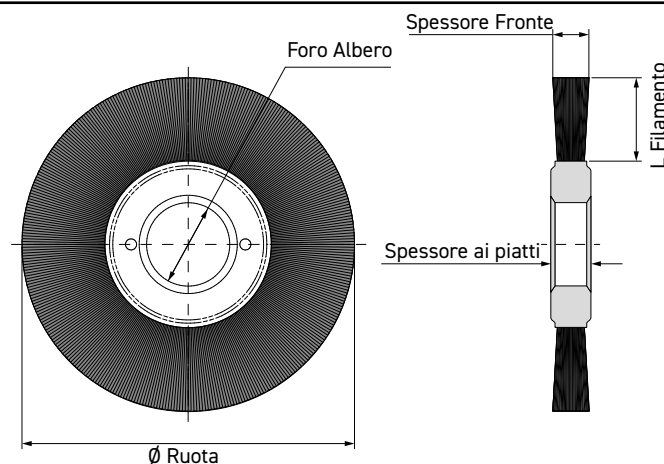

### Caratteristiche:

Spazzole a ruota con mozzo in metallo composito (in attesa di brevetto) che permette un significativo aumento della densità di riempimento e previene la rottura dei filamenti. Precise, stabili e costanti, assicurano prestazioni efficienti.

Il foro albero da 2" (50,8 mm) consente il montaggio diretto su vari tipi di macchina, senza la necessità di adattatori.

Le ruote CeraSef sono dotate di un filamento ceramico nero avanzato, che offre un'azione di taglio in testa fino al 400% superiore rispetto ai filamenti tradizionali in carburo di silicio e ossido di alluminio, per un'azione di sbavatura più rapida e aggressiva che riduce al minimo i tempi di ciclo.

Le spazzole a ruota Y100 hanno setole in filamento ceramico nero ondulato a sezione circolare.

Y100 Ø (mm)	Spazzola a ruota Codice Nr.	Ø /grana filamento	Foro albero (mm)	Spessore Fronte (mm)	Lunghezza Filamento (mm)	Spessore ai piatti (mm)	Max RPM (min <sup>-1</sup> )
150	Y32S168	0,70 / 120	50,8	19	25	24	4000
150	Y18S168	0,90 / 80	50,8	19	25	24	4000
150	Y42S168	1,10 / 120	50,8	19	25	24	4000
150	Y02S168	1,40 / 80	50,8	19	25	24	4000
200	Y62S168	0,70 / 120	50,8	22	50	24	4000
200	Y72S168	1,10 / 120	50,8	22	50	24	4000
200	Y82S168	1,40 / 80	50,8	22	50	24	4000
250	Y92S168	0,70 / 120	50,8 **	28	50	22,2	1800
250	Y28S168 ●	0,90 / 80	50,8 **	28	50	22,2	1800
250	Y03S168	1,10 / 120	50,8 **	28	50	22,2	1800
250	Y13S168	1,40 / 80	50,8 **	28	50	22,2	1800
305	Y23S168	0,70 / 120	50,8 **	32	75	22,2	1800
305	Y33S168	1,10 / 120	50,8 **	32	75	22,2	1800
305	Y43S168	1,40 / 80	50,8 **	32	75	22,2	1800
355	Y53S168	0,70 / 120	50,8 **	25	45	19	1800
355	Y80S168	0,90 / 80	50,8 **	25	45	19	1800
355	Y63S168	1,10 / 120	50,8 **	25	45	19	1800
355	Y73S168	1,40 / 80	50,8 **	25	45	19	1800
355	Y83S168 ●	0,70 / 120	50,8 **	32	100	22,2	1800
355	Y93S168	1,10 / 120	50,8 **	32	100	22,2	1800
355	Y04S168	1,40 / 80	50,8 **	32	100	22,2	1800

\*\*Doppia sede di chiavetta 12,7 x 6,35 (1/2" x 1/4")

● a richiesta

### Applicazioni:

- Sbavatura di precisione di componenti dopo lavorazione o rettifica
- Miglioramento della finitura delle superfici lavorate
- Pulizia e finitura leggera di metalli; levigatura leggera di legno e compositi



Y13S168



Y53S168

**Spazzole a Ruota tipo stretto con filamenti con abrasivo ceramico nero per sbavatura a macchina Y115 (per applicazioni gravose) Y116**



Art. Y115  
Y01S113

**CERASEF**

**Caratteristiche:**

Le spazzole a ruota tipo stretto Y115 per applicazioni gravose hanno mozzo in metallo e setole ad alta densità in filamento ceramico nero ondulato a sezione circolare.

Y115 Ø (mm)	Spazzola a ruota Codice Nr.	Ø /grana filamento	Foro albero (mm)	Spessore Fronte (mm)	Lunghezza Filamento (mm)	Spessore all'albero (mm)	Max RPM (min <sup>-1</sup> )
75	Y04S213	0,70 / 120	15,8 - 12,7	14	12,7	11,1	6000
75	Y14S213	0,90 / 80	15,8 - 12,7	14	12,7	11,1	6000
75	Y24S213	1,10 / 120	15,8 - 12,7	14	12,7	11,1	6000
75	Y64S213	1,40 / 80	15,8 - 12,7	14	12,7	11,1	6000
100	Y01S113	0,70 / 120	15,8 - 12,7	16	25,4	11,1	6000
100	Y07S213	0,90 / 80	15,8 - 12,7	16	25,4	11,1	6000
100	Y08S213	1,10 / 120	15,8 - 12,7	16	25,4	11,1	6000
100	Y09S213	1,40 / 80	15,8 - 12,7	16	25,4	11,1	6000

**Caratteristiche:**

Le spazzole a ruota tipo stretto Y116 hanno mozzo in metallo e setole ad alta densità in filamento ceramico nero ondulato a sezione circolare.



Art. Y116  
Y56S168

Y116 Ø (mm)	Spazzola a ruota Codice Nr.	Ø /grana filamento	Foro albero (mm)	Spessore Fronte (mm)	Lunghezza Filamento (mm)	Spessore all'albero (mm)	Max RPM (min <sup>-1</sup> )
75	Y46S168	0,70 / 120	12,7 - 9,5	9,5	12,7	11,1	6000
75	Y20S113	0,90 / 80	12,7 - 9,5	9,5	12,7	11,1	6000
75	Y10S113	1,10 / 120	12,7 - 9,5	9,5	12,7	11,1	6000
100	Y56S168	0,70 / 120	12,7 - 9,5	12,7	22	11,1	6000
100	Y30S113	0,90 / 80	12,7 - 9,5	12,7	22	11,1	6000
100	Y00S113	1,10 / 120	12,7 - 9,5	12,7	22	11,1	6000
100	Y50S113	1,40 / 80	12,7 - 9,5	12,7	22	11,1	6000
150	Y43S113	0,70 / 120	15,8 - 12,7	16	22	17,5	4500
150	Y53S113	0,90 / 80	15,8 - 12,7	16	22	17,5	4500
150	Y63S113	1,10 / 120	15,8 - 12,7	16	22	17,5	4500
150	Y73S113	1,40 / 80	15,8 - 12,7	16	22	17,5	4500

# Spazzole a Ruota per piccoli diametri con filamenti con abrasivo ceramico nero per sbavatura a macchina Y120

## CERASEF

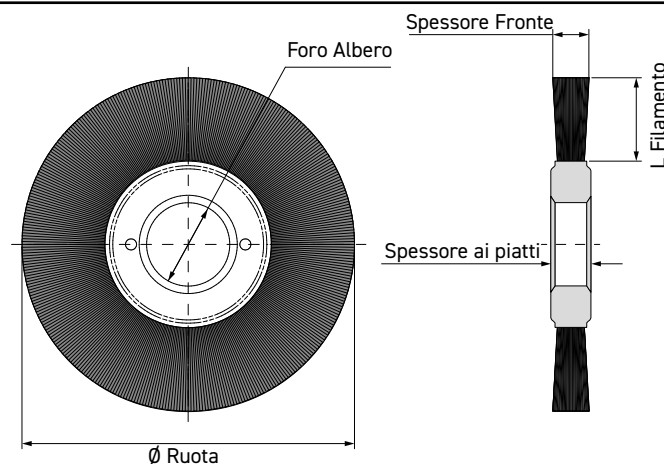

### Caratteristiche:

Ideali per le rientranze e gli elementi interni o per un'azione di spazzolatura mirata su un'area specifica.

Le ruote CeraSef sono dotate di un filamento ceramico nero avanzato, che offre un'azione di taglio in testa fino al 400% superiore rispetto ai filamenti tradizionali in carburo di silicio e ossido di alluminio.

Consentono un'azione di sbavatura più rapida e aggressiva che riduce al minimo i tempi di ciclo.

Le spazzole a ruota Y120 hanno mozzo in metallo e setole ad alta densità in filamento ceramico nero ondulato a sezione circolare.

Y120 Ø (mm)	Spazzola a ruota Codice Nr.	Ø /grana filamento	Ø Foro albero (mm)	Spessore Fronte (mm)	Lunghezza Filamento (mm)	Max RPM (min <sup>-1</sup> )
32	Y15S571	0,70 / 120	6,35 (1/4")	8	8	10000
38	Y14S571	0,70 / 120	12,7 (1/2")	9,5	6,4	10000
50	Y84S571	0,70 / 120	12,7 (1/2")	9,5	12,7	10000
50	Y55S571	0,90 / 80	12,7 (1/2")	9,5	12,7	10000
50	Y24S571	1,40 / 80	12,7 (1/2")	9,5	12,7	10000
63	Y65S571	0,70 / 120	15,9 (5/8")	12,7	17,5	10000
63	Y75S571	0,90 / 80	15,9 (5/8")	12,7	17,5	10000
75	Y56S571	0,70 / 120	12,7 (1/2")	12,7	25,4	10000
75	Y76S571	0,90 / 80	12,7 (1/2")	12,7	25,4	10000
75	Y86S571	1,10 / 120	12,7 (1/2")	12,7	25,4	10000
75	Y00S061	1,40 / 80	12,7 (1/2")	12,7	25,4	10000



Y15S571



Y56S571

### Applicazioni:

- Sbavatura di sedi di chiavette, scanalature, fori incrociati
- Lucidatura e finitura delle superfici interne di fori cilindrici

## Accessori

per spazzole a Ruota  
serie Y115 - Y116  
e serie Y120



# CERASEF

### Alberi per spazzole a ruota di piccolo diametro Y120 per il montaggio su pinza o mandrino

Ø Stelo (mm)	Ø Albero (mm)	L albero (mm)	L fusto (mm)	Per spazzole di Ø MASSIMO	Max RPM (min <sup>-1</sup> )	Codice Nr.
<b>Senza filetto</b>						
6,35 (1/4")	6,35 (1/4")	29	4,8	50	20000	<b>Y32S770</b>
<b>Filettati</b>						
12,7 (1/2")	6,35 (1/4")	19	19	75	25000	<b>Y42S770</b>
15,9 (5/8")	6,35 (1/4")	19	19	75	25000	<b>Y92S770</b>
12,7 (1/2")	6,35 (1/4")	22	19	75	20000	<b>Y12S770</b>
6,35 (1/4")	6,35 (1/4")	27	29	50	20000	<b>Y52S770</b>

### Albero Ø10 mm per spazzole a ruota Y120 con foro albero 1/4" (6,35 mm), filetto M4

Ø Stelo (mm)	Ø Albero (mm)	L totale (mm)	Filetto	Codice Nr.
6,35 (1/4")	10	92	M4	<b>Y990009</b>

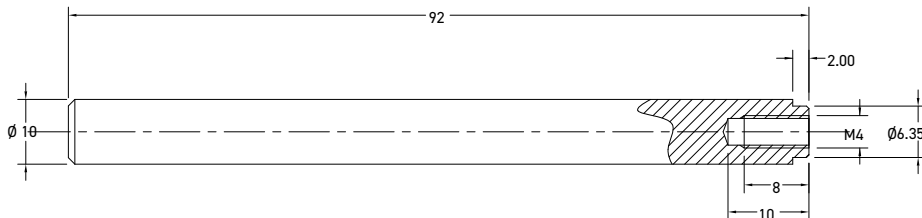

### Albero Ø16 mm per spazzole a ruota con foro 1/2" (12,7 mm), filetto M8, Y115, Y116, Y120

Ø Stelo (mm)	Ø Albero (mm)	L totale (mm)	Filetto	Codice Nr.
12,7 (1/2")	16	92	M8	<b>Y990010</b>

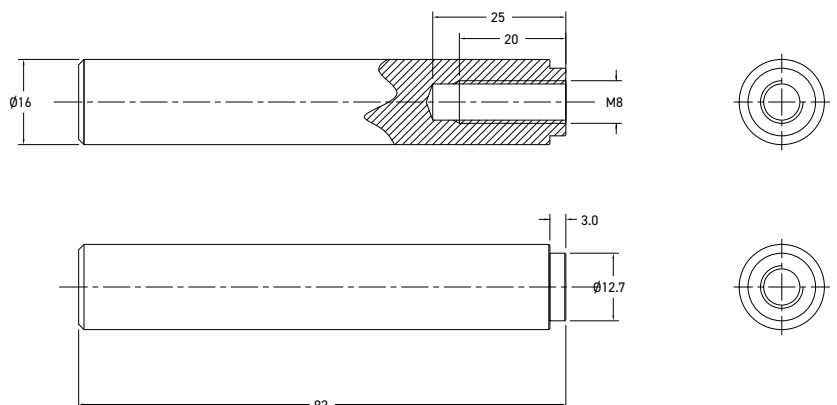

Y50S113





# Spazzole Cross-Hole per fori incrociati e diametri interni con filamenti con abrasivo ceramico nero Y125



Y21S271

## CERASEF

### Caratteristiche:

Le spazzole Y125 sono progettate per applicazioni automatizzate su CNC e macchine dedicate. Sono ideali per sbavare/finire l'interno fori e l'intersezione tra fori.

Eliminando la sbavatura a mano, migliorano la costanza ed uniformità tra i pezzi riducendo la manodopera diretta.

Sono disponibili in dimensioni che vanno da 22 mm (7/8") a 100 mm (4") e possono essere facilmente adattate al cambio utensili di un centro di lavoro utilizzando un mandrino porta-fresa o una pinza da 3/8".

Le spazzole per fori incrociati Y125 hanno setole ad alta densità in filamento ceramico nero ondulato a sezione circolare. Hanno gambo integrato  $\varnothing$  9,52 mm (3/8").

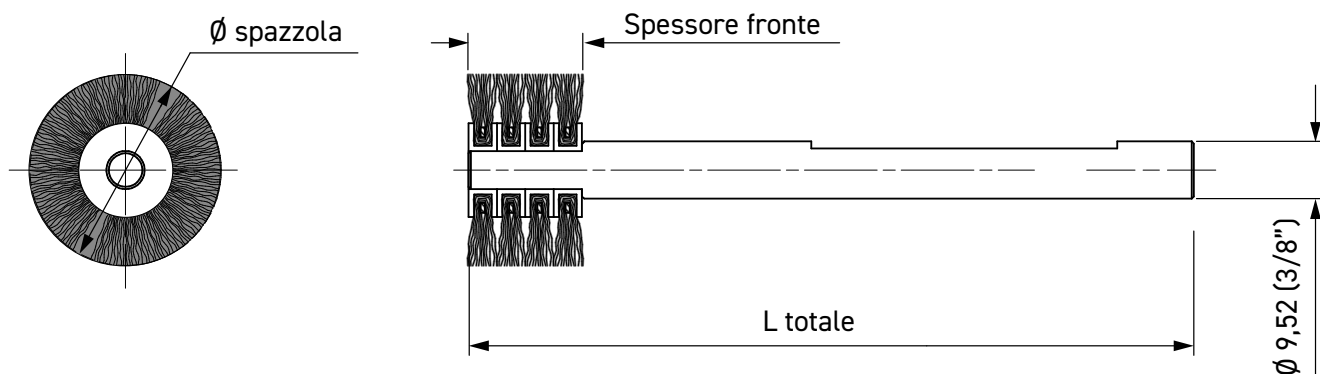

Y125 Ø (mm)	Spazzola Cross Hole Codice Nr.	Ø /grana filamento	L totale (mm)	Spessore Fronte (mm)	Max RPM (min <sup>-1</sup> )
22	Y60S271	0,70 / 120	120	20	8000
25	Y80S271	0,70 / 120	120	20	8000
32	Y01S271	0,70 / 120	120	20	8000
38	Y21S271	0,70 / 120	127	25	8000
50	Y51S271	0,70 / 120	83	25	6000
63	Y71S271	1,40 / 80	83	25	6000
75	Y05S168	0,70 / 120	83	25	6000
75	Y15S168	1,10 / 120	83	25	6000
75	Y25S168	1,40 / 80	83	25	6000
100	Y45S168	0,70 / 120	83	25	6000
100	Y55S168	1,10 / 120	83	25	6000
100	Y65S168	1,40 / 80	83	25	6000

**Nota:** tutte le spazzole Cross Hole Y125 hanno un pianetto di lunghezza 50 mm sul gambo per poter essere utilizzate in mandrini porta fresa. In alternativa possono essere prese su pinza da 3/8".

# Spazzole Cross-Hole per fori incrociati e diametri interni con filamenti con abrasivo ceramico nero Y125

Y65S168



## CERASEF

**Diametro di interpolazione** =  $(\varnothing \text{ foro principale} - 0,975) \times \varnothing \text{ spazzola}$

### Percorso utensile per la sbavatura di fori incrociati:

Un percorso utensile efficace per la maggior parte dei lavori di sbavatura di fori incrociati è l'interpolazione circolare, che utilizza le seguenti linee guida per determinare il diametro dell'interpolazione.

Questa deve avvenire all'interno del foro principale ad una profondità alla quale il centro del fronte della spazzola si trovi in corrispondenza del centro del foro secondario che genera la bava.

### Percorso utensile per la finitura dei fori:

Le spazzole Cross Hole Y125 possono essere utilizzate per migliorare il grado di finitura superficiale dei fori.

Il miglior percorso utensile consiste normalmente nell'interpolazione elicoidale del foro.

Le raccomandazioni di cui sopra per velocità, avanzamento e diametro di interpolazione sono valide anche per la finitura di fori.

L'uso del refrigerante è altamente raccomandato per ottenere la migliore finitura possibile.



Y60S271



Sbavatura interna di una testa di cilindro



Y71S271

# Accessori e ricambi per spazzole Cross-Hole per fori incrociati e diametri interni con filamenti con abrasivo ceramico nero Y125

## CERASEF



Y19S930 prolunga riutilizzabile



Testina di ricambio (speciale a richiesta)



Y39S930 albero riutilizzabile per testine speciali

### Prolunga riutilizzabile per spazzole Cross Hole con gambo da $\varnothing 9,52$ mm

Prolunga per spazzola Cross Hole Codice Nr.	$\varnothing$ foro (mm)	$\varnothing$ Albero (mm)	L albero (mm)	Grano di fissaggio (2x)
Y19S930	9,52 (3/8")	9,52 (3/8")	203	1/4-28 UNF x .25"

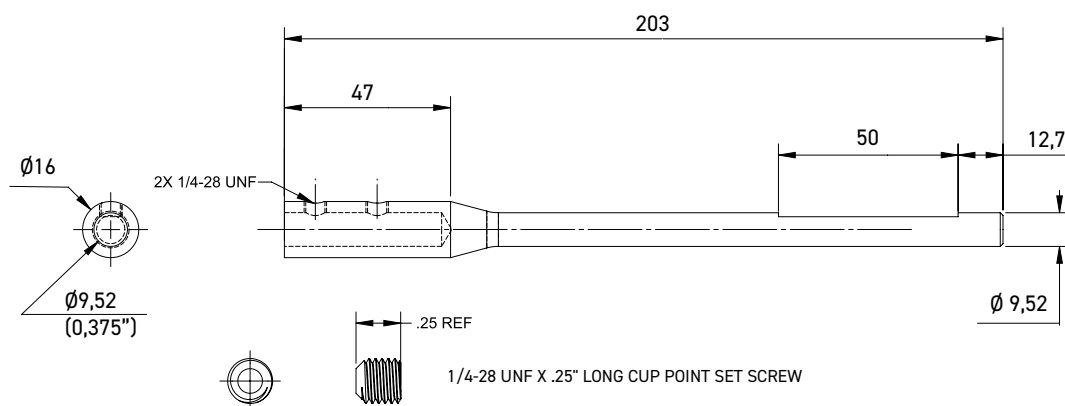

### Soluzioni personalizzabili per la sbavatura dei fori incrociati

#### Testine di spazzole Cross Hole di ricambio e alberi riutilizzabili

Nelle applicazioni ad alta produzione, gli alberi riutilizzabili riducono i costi di produzione consentendo l'utilizzo di testine di ricambio meno costose. Le testine sono realizzate su ordinazione in diametri che vanno da 22 mm (7/8") a 38 mm (1-1/2") con spessore del fronte da 6,35 mm (1/4") a 25,4 mm (1"). Sono disponibili con perni da 3/16" e 1/4". Il diametro del perno dipende dall'applicazione e determina la densità della spazzola.

Y39S930 albero riutilizzabile per testine speciali

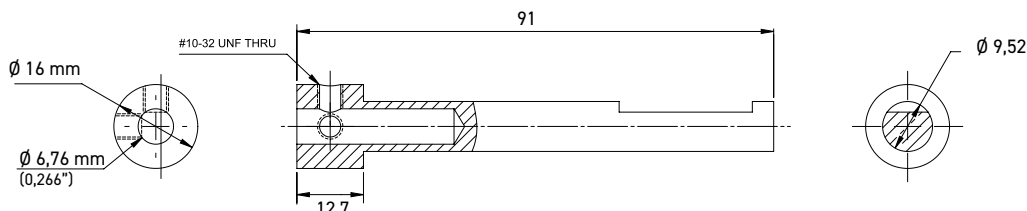



# Spazzole a Tazza

## Massima densità di filamento impregnato di abrasivo ceramico nero per sbavatura a macchina Y130



# CERASEF

### Caratteristiche:

Realizzate con una configurazione di filamenti a settore e una lunghezza delle setole maggiore per una maggiore aggressività, una maggiore conformabilità e una maggiore durata del prodotto rispetto alle spazzole a disco monofilamento, che presentano una distribuzione di setole singole e corte.

Le spazzole a disco CeraSef Y130 sono dotate dell'avanzato filamento in ceramica nera, che offre un'azione di taglio fino al 400% superiore rispetto ai filamenti tradizionali in carburo di silicio e ossido di alluminio, per un'azione di sbavatura più rapida e aggressiva, con tempi di ciclo minimi e massima durata.

Tutte le spazzole a disco CeraSef sono prodotte con un nuovo processo che consente di ottenere una superficie della

spazzola molto uniforme e piatta rispetto alla costruzione tradizionale, che utilizza un supporto stampato. L'elevata precisione dimensionale di questi utensili fa sì che le spazzole siano adatte alle applicazioni più critiche e che abbiano prestazioni più costanti dal primo all'ultimo pezzo. Inoltre, i supporti in polimero lavorati sono progettati per essere montati direttamente su un mandrino portafresa standard, per un comodo utilizzo nei centri di lavorazione CNC.

### Applicazioni:

- Sbavatura di superfici piane su componenti lavorati
- Miglioramento delle caratteristiche della texture su superfici lavorate
- Sbavatura di fusioni o forgiati dopo la spianatura
- Sfumatura dei testimoni di lavorazione dopo la fresatura o la rettifica

Y130 Ø (mm)	Spazzola Cross Hole Codice Nr.	Ø /grana filamento	Lunghezza Filamento (mm)	Ø Foro Albero (mm)	Max RPM (min <sup>-1</sup> )
100	Y21S168	0,70 / 120	38	31,75	2500
100	Y31S168	1,10 / 120	38	31,75	2500
100	Y40S286* ●	1,10 / 120	38	31,75	2500
100	Y41S168*	1,40 / 80	38	31,75	2500
150	Y51S168	0,70 / 120	38	31,75	2500
150	Y61S168	1,10 / 120	38	31,75	2500
150	Y71S168*	1,40 / 80	38	31,75	2500
200	Y14S168 ●	0,70 / 120	38	31,75	2000
200	Y24S168	1,10 / 120	38	31,75	2000
200	Y34S168*	1,40 / 80	38	31,75	2000
250	Y52S168 ●	0,70 / 120	38	31,75	2000
250	Y12S168	1,10 / 120	38	31,75	2000
250	Y22S168*	1,40 / 80	38	31,75	2000
<b>Filamento rettangolare</b>					
100	Y76S168*	■ / 80	38	31,75	2500
150	Y89S168*	■ / 80	38	31,75	2500
200	Y99S168* ●	■ / 80	38	31,75	2000

\*massima densità

● a richiesta

# Spazzole a Tazza

Massima densità di filamento  
impregnato di abrasivo ceramico  
nero per sbavatura a macchina  
**Y130**

Ø250 Y22S168

Ø150 Y51S168



# CERASEF

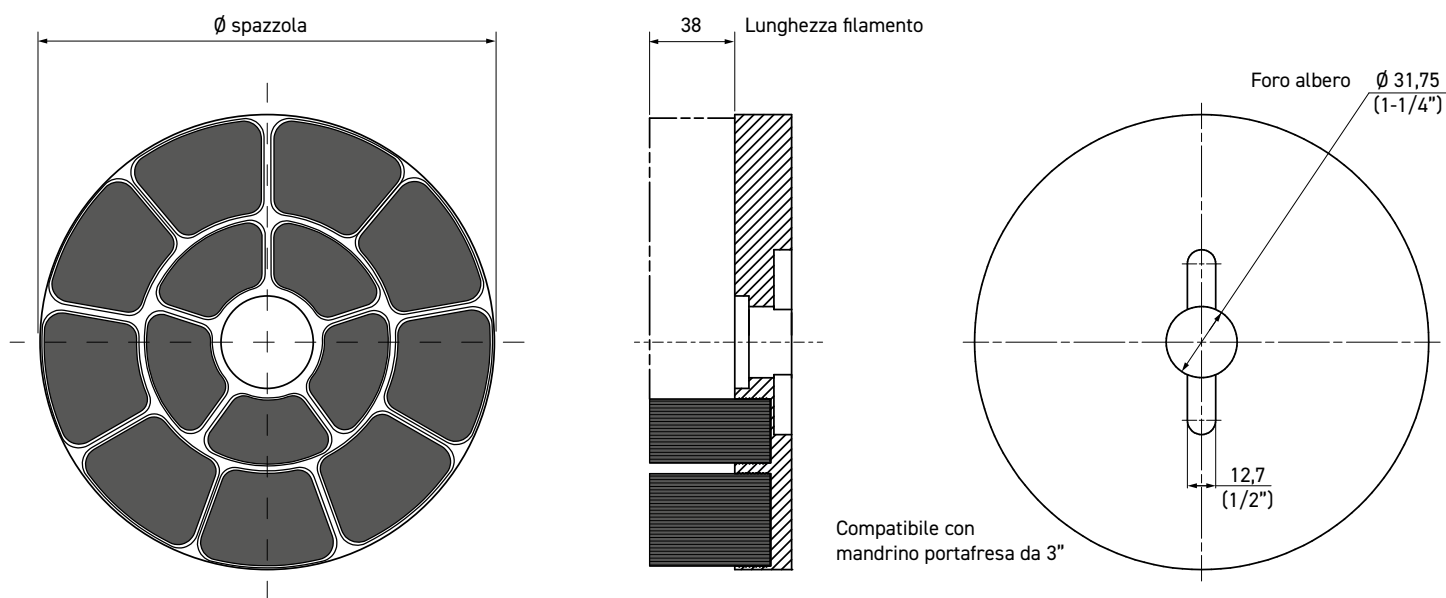

## Raccomandazioni per l'avanzamento

La velocità di avanzamento è determinata dalla portata della sbavatura, della raggiatura degli spigoli o della finitura superficiale richiesta e dal tipo di materiale da lavorare. In genere è specifica per l'applicazione. Un avanzamento più ridotto comporta un'azione di spazzolatura più aggressiva. In base all'azione di spazzolatura desiderata per un'applicazione specifica, la velocità di avanzamento può essere aumentata o diminuita.



# Spazzole a **Mini Tazza**

## Massima densità di filamento impregnato di abrasivo ceramico nero per sbavatura a macchina

### **Y135 - Y135R**

**Y135**  
**Art. Y33S758**



# CERASEF

**Applicazioni:** Spazzole a tazza di piccoli diametri con filamenti impregnati di abrasivo ceramico nero ad alta intensità, per sbavatura e finitura di superfici piane.

**Y135R ha filamento rettangolare**

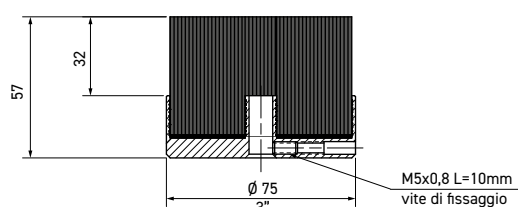
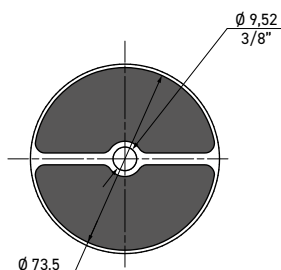
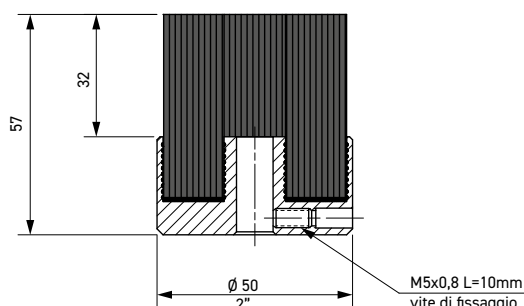
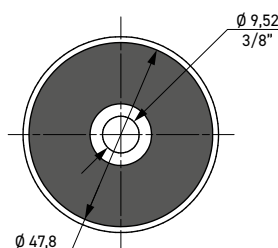

Ø Mini Tazza Art. 135	Spazzola Mini Disco Codice Nr.	Ø /grana filamento	L Filamento (mm)	Max RPM (min <sup>-1</sup> )
50	Y60S168	0,70 / 120	32	4500
50	Y83S758	0,90 / 80	32	4500
50	Y70S168	1,10 / 120	32	4500
50	Y33S758	1,40 / 80	32	4500

Ø Mini Tazza Art. 135R	Spazzola Mini Disco Codice Nr.	■ / grana	L Filamento (mm)	Max RPM (min <sup>-1</sup> )
50	Y63S758	■ / 80	32	4500

Ø Mini Tazza Art. 135	Spazzola Mini Disco Codice Nr.	Ø /grana filamento	L Filamento (mm)	Max RPM (min <sup>-1</sup> )
75	Y90S168	0,70 / 120	32	4500
75	Y31S068	0,90 / 80	32	4500
75	Y01S168	1,10 / 120	32	4500
75	Y11S168	1,40 / 80	32	4500

Ø Mini Tazza Art. 135R	Spazzola Mini Disco Codice Nr.	■ / grana	L Filamento (mm)	Max RPM (min <sup>-1</sup> )
75	Y41S068	■ / 80	32	4500

**Accessori per spazzole a Tazza**  
**Massima densità di filamento**  
**impregnato di abrasivo ceramico**  
**nero per sbavatura a macchina**  
**Y130 - Y135 - Y135R**

**CERASEF**

Albero metrico Y99S930  
 gambo Ø20



**Albero con gambo metrico Ø20 mm**  
**per spazzole a tazza con trascinamento Y130**

Ø Stelo (mm)	Ø Albero (mm)	L totale (mm)	Filetto	Codice Nr.
20	10	90	M4	Y99S930

**Alberi per spazzole a tazza con**  
**trascinamento Y135 - Y135R**

Ø Stelo (mm)	Codice Nr.
10	Y14S098
12,7	Y33S089



Y33098

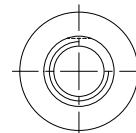
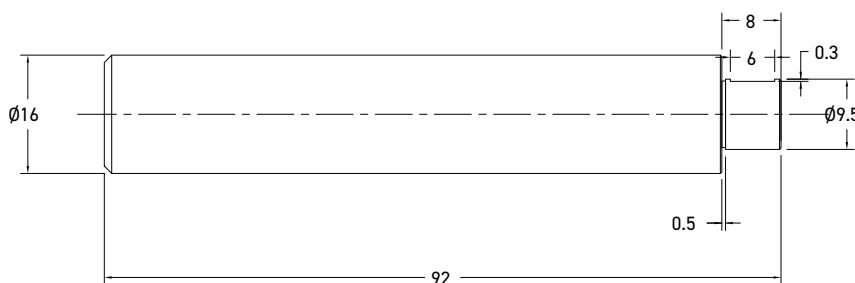
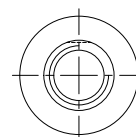
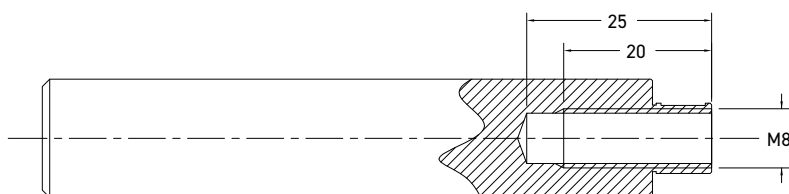

**Albero Ø16 mm per spazzole a mini tazza Ø50 e Ø75 serie Y135 e Y135R**

Ø Stelo (mm)	Ø Albero (mm)	L totale (mm)	Filetto	Codice Nr.
9,5 (3/8")	16	92	M8	Y990011

# Spazzole tipo Pennello impregnate di abrasivo ceramico nero per sbavatura a macchina Y140



## CERASEF

### Caratteristiche:

Dotate di uno stelo integrato  $\varnothing 6,35$  mm (1/4") per un comodo montaggio in un portautensile o pinza, le spazzole tipo pennello CeraSef Y140 sono adatte per trattare recessi e particolari interni, o per fornire un'azione di spazzolatura mirata su un'area specifica di un pezzo.

### Applicazioni:

- Sbavatura di piccole aree incassate e dettagli interni dei pezzi
- Finitura di scanalature e superfici incassate su pezzi lavorati

Y140 $\varnothing$ (mm)	Spazzola Cross Hole Codice Nr.	$\varnothing$ /grana filamento	Esposizione Filamento* (mm)	L totale (mm)	RPM raccomandata (min <sup>-1</sup> )	Max RPM (min <sup>-1</sup> )
10	Y89S068	0,70 / 120	6,35	60	4500-5000	10000
10	Y99S068	1,10 / 120	6,35	60	4500-5000	10000
13	Y00S168	0,70 / 120	6,35	62	4500-5000	10000
13	Y10S168	1,10 / 120	6,35	62	4500-5000	10000
20	Y20S168	0,70 / 120	6,35	62	4200-4500	10000
20	Y30S168	1,10 / 120	6,35	62	4200-4500	10000
25	Y40S168	0,70 / 120	6,35	67	3500-3800	10000
25	Y50S168	1,10 / 120	6,35	67	3500-3800	10000
25	Y79S068	1,40 / 80	6,35	67	3500-3800	10000

\*Lunghezza del filamento oltre la banda termoretraibile



# Scovoli con setole impregnate di abrasivo ceramico nero per sbavatura a mano e a macchina Y150



## CERASEF

### Caratteristiche:

Assicurano una sbavatura e finitura rapida in aree di difficile accesso come fori, fessure, superfici filettate ed altro.

Sono adatti sia ai centri di lavoro che a trapani a colonna o utensili pneumatici.

### Applicazioni:

- Sbavatura intersezione tra fori in corpi valvola e collettori lavorati a macchina
- Finitura e pulitura di fori di piccolo diametro

Y150 Ø (mm)	Scovolo Codice Nr.	Ø /grana filamento	L parte abrasiva* (mm)	L totale (mm)	Ø gambo (mm)
6,0	Y20S622	0,70 / 120	25	90	6,35
6,35	Y75S712 ●	0,70 / 120	25	90	6,35
7,0	Y30S622	0,70 / 120	25	90	6,35
8,0	Y40S622	0,70 / 120	25	90	6,35
9,0	Y50S622	0,70 / 120	25	90	6,35
9,53	Y85S712	0,70 / 120	25	90	6,35
10,0	Y60S622	0,70 / 120	25	90	6,35
11,0	Y70S622	0,70 / 120	25	90	6,35
12,0	Y80S622	0,70 / 120	25	90	6,35
12,7	Y95S712	0,70 / 120	25	90	6,35
14,0	Y01S622	0,70 / 120	25	90	6,35
14,29	Y06S712 ●	0,70 / 120	25	90	6,35
15,88	Y16S712	0,70 / 120	25	90	6,35
18,0	Y41S622	0,70 / 120	25	90	6,35
19,05	Y26S712	0,70 / 120	25	90	6,35
20,0	Y61S622	0,70 / 120	25	90	6,35
22,23	Y36S712	0,70 / 120	25	90	6,35
25,4	Y46S712	0,70 / 120	25	90	6,35
31,75	Y56S712 ●	0,70 / 120	25	90	6,35



**Scovoli per piccoli diametri**  
**con setole impregnate di micro**  
**abrasivo (ossido di alluminio) per**  
**sbavatura a mano e a macchina**  
**Y335**



# CERASEF

**Applicazioni:**

- Sbavatura ultra fine e pulitura di fori di piccolo diametro

Y335 Ø (mm)	Per foro Ø (mm)	Scovolo Codice Nr.	L parte abrasiva* (mm)	L totale (mm)	Ø gambo (mm)
<b>Grana 2000</b>					
0,76	0,79	Y00S962	12,7	100	0,4
1,27	1,19	Y10S962	12,7	100	0,6
1,91	1,60	Y20S962	19,1	100	0,8
2,29	1,98	Y30S962	19,1	100	1,0
2,67	2,39	Y40S962	25,4	100	1,0
3,18	2,77	Y50S962	25,4	100	1,6
3,43	3,18	Y60S962	25,4	100	1,9
<b>Grana 600</b>					
4,19	4,0	Y70S962	25,4	127	2,2
4,83	4,8	Y80S962	25,4	127	2,2
6,60	6,4	Y90S962	25,4	127	2,9
8,26	8,0	Y01S962	25,4	127	2,9
9,78	9,5	Y11S962	25,4	127	3,7
13,08	12,7	Y21S962	25,4	127	4,9
16,26	15,9	Y31S962 ●	25,4	127	4,9
19,43	19,1	Y41S962 ●	25,4	127	5,4
22,61	22,2	Y51S962 ●	25,4	127	5,4





# Spazzole flessibili di piccolo diametro tipo CROSSFLEX con setole impregnate di carburo di silicio per sbavatura a mano e a macchina



## CERASEF

### Caratteristiche:

CROSSFLEX offre agli operatori la giusta combinazione di prestazioni e costo per le applicazioni di lucidatura professionali. I filamenti flessibili forniscono la giusta pressione per creare una lucidatura ideale, un foro dopo l'altro. È l'utensile ideale per creare motivi a tratteggio incrociato per migliorare la ritenzione dell'olio e aumentare l'efficienza del pezzo. Il robusto sistema autocentrante lascia una finitura superficiale liscia e uniforme, priva di bave metalliche, sia che si utilizzi in un'applicazione manuale o automatizzata.

#### • Finitura desiderata

CrossFlex offre un'ampia gamma di grane e dimensioni che consentono agli operatori di ottenere la finitura desiderata.

#### • Rimozione di bave importanti

Il maggiore contatto tra la spazzola e il pezzo garantisce la rimozione delle bave più pesanti, superando le spazzole tubolari in nylon standard.

#### • Lunga durata

Le spazzole CrossFlex hanno una lunga durata operativa, riducendo il costo totale di utilizzo rispetto ad altre opzioni di spazzole.

#### • Steli di nylon flessibili

Distribuiscono la pressione in modo uniforme e si autocentrano nel pezzo per creare un'affilatura ideale.

#### • Schema a croce coerente

Favorisce l'alloggiamento delle fasce elastiche e trattiene l'olio per la lubrificazione nei cilindri di combustione.

#### • Spazzole per pinza di serraggio

Offrono una vera rotazione centrale e un eccezionale bilanciamento delle spazzole per applicazioni automatiche o manuali.

### Applicazioni:

Le **spazzole CROSSFLEX di piccolo diametro** sono ideali per sbavare intersezioni di fori trasversali di piccolo diametro.

### Spazzole CROSSFLEX di piccolo diametro

Per foro Ø (mm)	L abrasivo (mm)	L totale (mm)	Ø gambo (mm)	Max RPM (min <sup>-1</sup> )	●	●	●	○
					Grana 120 Codice Nr.	Grana 180 Codice Nr.	Grana 240 Codice Nr.	Grana 320 Codice Nr.
4,5	20	152	2,1	1000	-	Y50S143	Y60S143	Y70S143
4,7625	20	152	2,1	1000	-	Y80S143	Y90S143	Y01S143
5	40	200	2,1	1000	Y11S143	Y21S143	Y31S143	Y41S143
5,5	40	200	2,1	1000	Y51S143	Y61S143	Y71S143	Y81S143
6	40	200	2,5	1000	Y91S143	Y02S143	Y12S143	Y22S143
6,35	40	200	2,5	1000	Y32S143	Y42S143	Y52S143	Y62S143
7	50	200	3,3	900	Y72S143	Y82S143	Y92S143	Y03S143
8	50	200	3,6	900	Y13S143	Y33S143	Y43S143	Y53S143
9	50	200	3,6	900	Y63S143	Y73S143	Y83S143	Y93S143
9,5	50	200	3,6	900	Y14S143	Y24S143	Y34S143	Y44S143
10	50	200	3,6	900	Y54S143	Y64S143	Y74S143	Y84S143
11	50	200	3,6	900	Y94S143	Y05S143	Y15S143	Y25S143
12	50	200	4	900	Y35S143	Y45S143	Y55S143	Y65S143
12,7	63	200	4,4	900	Y85S143	Y95S143	Y06S143	Y16S143
14	63	200	5	900	Y26S143	Y36S143	Y46S143	Y56S143
16	63	200	5	900	Y66S143	Y76S143	Y86S143	Y96S143
18	63	200	5	900	Y07S143	Y17S143	Y27S143	Y37S143
19	63	200	5	900	Y47S143	Y57S143	Y67S143	Y77S143
20	63	200	5	900	Y87S143	Y97S143	Y08S143	Y18S143
22	63	200	5,4	900	Y28S143	Y38S143	Y48S143	Y58S143
23,8	76	200	5,4	900	Y68S143	Y78S143	Y88S143	Y98S143



## Spazzole flessibili di piccolo diametro tipo CROSSFLEX con setole impregnate di carburo di silicio per sbavatura a mano e a macchina



# CERASEF

### Applicazioni:

Le spazzole **CROSSFLEX di piccolo diametro COLLET READY** in carburo di silicio sono indicate per l'impiego standard in applicazioni automatizzate e per ridurre il run-out.





### Vantaggi delle spazzole COLLET READY:

- Riduzione del run-out
- Si rafforza ed irrobustisce l'albero della spazzola per una maggiore stabilità e portata complessiva
- Ingaggio solido con il portautensili

### Grana abrasiva delle spazzole crossflex



### Spazzole CROSSFLEX di piccolo diametro COLLET READY

Per foro Ø (mm)	L abrasivo (mm)	L totale (mm)	Ø gambo (mm)	Max RPM (min <sup>-1</sup> )				
					Grana 120 Codice Nr.	Grana 180 Codice Nr.	Grana 240 Codice Nr.	Grana 320 Codice Nr.
4,5	20	152	4 (5/32")	1000	-	Y89S243	Y99S243	Y95S343
4,76	20	152	4 (5/32")	1000	-	Y00S343	Y10S343	Y20S343
5	40	200	4 (5/32")	1000	Y30S343	Y40S343	Y50S343	Y60S343
5,5	40	200	4 (5/32")	1000	Y70S343	Y80S343	Y90S343	Y01S343
6	40	200	4 (5/32")	1000	Y11S343	Y21S343	Y31S343	Y41S343
6,35	40	200	4 (5/32")	1000	Y51S343	Y61S343	Y71S343	Y81S343
7	50	200	6,35 (1/4")	900	Y91S343	Y02S343	Y12S343	Y22S343
8	50	200	6,35 (1/4")	900	Y32S343	Y42S343	Y52S343	Y62S343
9	50	200	6,35 (1/4")	900	Y72S343	Y82S343	Y92S343	Y03S343
9,5	50	200	6,35 (1/4")	900	Y13S343	Y23S343	Y33S343	Y43S343
10	50	200	6,35 (1/4")	900	Y53S343	Y63S343	Y73S343	Y83S343
11	50	200	6,35 (1/4")	900	Y93S343	Y04S343	Y14S343	Y24S343
12	50	200	8	900	Y34S343	Y44S343	Y54S343	Y64S343
12,7	63	200	8	900	Y74S343	Y84S343	Y94S343	Y05S343
14	63	200	8	900	Y15S343	Y25S343	Y35S343	Y45S343
16	63	200	8	900	Y55S343	Y65S343	Y75S343	Y85S343

**Spazzole flessibili di medio diametro tipo CROSSFLEX con setole impregnate di carburo di silicio per sbavatura a mano e a macchina**



# CERASEF

**Applicazioni:**

Le spazzole **CROSSFLEX di medio diametro** in carburo di silicio per la sbavatura di fori incrociati sono indicate per l'impiego standard. Ideali per modificare la finitura superficiale di fori lavorati e per sbavare il diametro interno delle fusioni.



**Spazzole CROSSFLEX di medio diametro**

Per foro Ø (mm)	L abrasivo (mm)	L totale (mm)	Ø gambo (mm)	Max RPM (min <sup>-1</sup> )	●	●	●	○
					Grana 120 Codice Nr.	Grana 180 Codice Nr.	Grana 240 Codice Nr.	Grana 320 Codice Nr.
25,4	75	200	5,4	900	Y09S243	Y19S243	Y29S243	Y39S243
29	75	200	5,7	800	Y49S243	Y59S243	Y69S243	Y79S243
31,8	75	200	6,4	800	Y89S243	Y99S243	Y00S243	Y10S243
35	75	200	6,4	800	Y20S243	Y30S243	Y40S243	Y50S243
38	75	200	6,4	800	Y60S243	Y70S243	Y80S243	Y90S243
41	75	200	6,4	800	Y01S243	Y11S243	Y21S243	Y31S243
45	75	200	6,4	800	Y41S243	Y51S243	Y61S243	Y71S243
47,6	75	200	6,4	800	Y81S243	Y91S243	Y02S243	Y12S243
51	75	200	6,4	800	Y22S243	Y32S243	Y42S243	Y52S243
54	75	200	7,2	700	Y62S243	Y72S243	Y82S243	Y92S243
57	75	200	7,2	700	Y03S243	Y13S243	Y23S243	Y33S243
60	75	200	7,2	700	Y43S243	Y53S243	Y63S243	Y73S243
64	75	200	7,2	700	Y83S243	Y93S243	Y04S243	Y14S243
67	75	200	7,2	700	Y24S243	Y34S243	Y44S243	Y54S243
70	75	200	7,2	700	Y64S243	Y74S243	Y84S243	Y94S243
73	75	200	7,2	700	Y05S243	Y15S243	Y25S243	Y35S243
76	140	200	7,9	700	Y45S243	Y55S243	Y65S243	Y75S243

**Spazzole CROSSFLEX di medio diametro PER APPLICAZIONI GRAVOSE**

Per foro Ø (mm)	L abrasivo (mm)	L totale (mm)	Ø gambo (mm)	Max RPM (min <sup>-1</sup> )	●	●	●	○
					Grana 120 Codice Nr.	Grana 180 Codice Nr.	Grana 240 Codice Nr.	Grana 320 Codice Nr.
76	140	343	7,9	700	Y85S243	Y95S243	Y06S243	Y16S243
83	140	343	7,9	700	Y26S243	Y36S243	Y46S243	Y56S243
89	140	343	7,9	700	Y66S243	Y76S243	Y86S243	Y96S243

**Spazzole flessibili di grande diametro tipo CROSSFLEX per applicazioni gravose con setole impregnate di carburo di silicio per sbavatura a mano e a macchina**



**CERASEF**

**Applicazioni:**

Le spazzole **CROSSFLEX di grande diametro** in carburo di silicio sono indicate per applicazioni gravose. Ideali per la creazione di tratteggi nei cilindri di combustione.



**Spazzole CROSSFLEX di grande diametro PER APPLICAZIONI GRAVOSE**

Per foro Ø (mm)	L abrasivo (mm)	L totale (mm)	Ø gambo (mm)	Max RPM (min <sup>-1</sup> )	●	●	●	○
					Grana 120 Codice Nr.	Grana 180 Codice Nr.	Grana 240 Codice Nr.	Grana 320 Codice Nr.
95	140	343	7,9	700	<b>Y07S243</b>	<b>Y17S243</b>	<b>Y27S243</b>	<b>Y37S243</b>
101	165	343	8,8	600	<b>Y47S243</b>	<b>Y57S243</b>	<b>Y67S243</b>	<b>Y77S243</b>
108	165	343	8,8	600	<b>Y87S243</b>	<b>Y97S243</b>	<b>Y08S243</b>	<b>Y18S243</b>
114	165	343	8,8	600	<b>Y28S243</b>	<b>Y38S243</b>	<b>Y48S243</b>	<b>Y58S243</b>
127	165	457	8,8	600	<b>Y68S243</b>	<b>Y78S243</b>	<b>Y88S243</b>	<b>Y98S243</b>
140	165	457	10,2	600	<b>Y09S243</b>	<b>Y19S243</b>	<b>Y29S243</b>	<b>Y39S243</b>
152	165	457	10,2	600	<b>Y49S243</b>	<b>Y59S243</b>	<b>Y69S243</b>	<b>Y79S243</b>

**ESECUZIONI SPECIALI:**

Sappiamo che non tutte le applicazioni di finitura o sbavatura hanno una soluzione standard. Nei casi in cui le applicazioni richiedono dimensioni, lunghezze o abrasivi dedicati, gli specialisti di CERASEF collaborano con voi per fornire spazzole CrossFlex personalizzate per la vostra specifica applicazione.

- Dimensioni personalizzate per i vostri specifici diametri di foro
- Spazzole con steli più corti o più lunghi per la vostra particolare applicazione
- Predisposizione per pinze di serraggio o altri metodi di connessione
- Opzioni in una varietà di abrasivi, tra cui **carburo di silicio**, **ossido di alluminio**, **allumina zirconica** e **abrasivo ceramico**





# Countersinks

Fraises | Senker | Svasatori | Pogłębiacze

From the original M.A.Ford® single flute Uniflute® countersink for unrivalled economical, chatter free machining in both carbide and HSS options to multiple flute tools for increased feed rates for reduced chip loads, our wide choice and high quality countersinks provide the perfect solution.

FR

“Depuis la fraise originale M.A.Ford® une dent Uniflute® économiquement inégalable, ne générant pas de broutage, disponibles en carbure et HSS, en passant par les outils à goujures multiples pour des vitesses d’avance plus élevées et des copeaux réduits, notre large choix de fraises de grande qualité vous donnent accès aux meilleures solutions.”

DE

Unsere große Auswahl an Senkern und deren hochwertige Qualität stellen die perfekte Lösung zur Verfügung: vom originalen M.A.Ford® Uniflute®-Senker mit einer Schneide zur einzigartigen, wirtschaftlichen und ratterfreien Bearbeitung in sowohl Hartmetall- als auch HSS-Ausführungen bis zu Werkzeugen mit mehreren Schneiden für erhöhte Vorschubgeschwindigkeiten und vermindertes Zerspanungsvolumen.

IT

La soluzione perfetta per la svasatura: ampia scelta e alta qualità. Svasatori originali M.A.Ford® Uniflute® monotagliente, disponibili sia in HSS che in metallo duro, per la svasatura efficiente e senza vibrazioni. Svasatori multitagliente per alto avanzamento con riduzione del carico per tagliente.

PL

W naszej ofercie znajdują się jednostrzowe pogłębiacze Uniflute®, które oferują nieporównywalne wartości ekonomiczne i techniczne. Polecamy również opcje z wieloma rowkami wiórowymi które oferują wysokie wartości posuwu. Obydwie grupy produktów dostępne są w wersji HSS i z węgla.

Page

<b>Uniflute® Carbide Countersink Single Flute</b> Series 60 Uncoated	198
<b>Uniflute® HSS Countersink Single Flute</b> Series 61 Steam Treated	198
<b>Uniflute® HSS Countersink Single Flute</b> Series 61B ALtima® Blaze Coated	199
<b>Uniflute® HSS Countersink Single Flute</b> Series 61T TiN Coated	199
<b>Uniflute® HSS Countersink Sets Single Flute</b> Series 61 Steam Treated & Series 61T TiN Coated	200
<b>Vibration Free HSS Countersink 6 Flute</b> Series 78 Uncoated	201
<b>Vibration Free HSS Countersink 6 Flute</b> Series 79 Steam Treated	201
<b>Vibration Free HSS Countersink 6 Flute</b> Series 79B ALtima® Blaze Coated & 79T TiN Coated	202
<b>Vibration Free HSS Countersink Set 6 Flute</b> Series 79 Steam Treated & 79T TiN Coated	203
<b>HSS Aircraft Countersink 3 Flute</b> Series 92 Bright Finish	204
<b>HSS Aircraft Countersink Set 3 Flute</b> Series 92 Bright Finish Set	204
<b>HSS Countersink 3 Flute</b> Series 893T TiN Coated	205
<b>HSS Countersink Set 3 Flute</b> Series 893T TiN Coated Set	205
<b>Technical Information</b>	206 - 208



FORDMAX

Countersinks  
Fraises  
Senker  
Svasatori  
Pogłębiacze

## Uniflute® Carbide Countersink - Single Flute Series 60 Uncoated

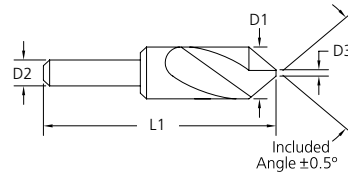

60°	82°	90°	100°	Tool Dimensions			
Tool No.	Tool No.	Tool No.	Tool No.	D1	D2	D3 (Max)	L1
60012501	60012502	60012503	60012504	1/8" 3.2mm	1/8" 3.2mm	0.030" 0.8mm	1-1/2" 38.1mm
60018701	60018702	60018703	60018704	3/16" 4.8mm	3/16" 4.8mm	0.045" 1.1mm	1-1/2" 38.1mm
60025001	60025002	60025003	60025004	1/4" 6.4mm	1/4" 6.4mm	0.045" 1.1mm	2" 50.8mm
60037501	60037502	60037503	60037504	3/8" 9.5mm	1/4" 6.4mm	0.06" 1.5mm	2" 50.8mm
60050001	60050002	60050003	60050004	1/2" 12.7mm	1/4" 6.4mm	0.06" 1.5mm	2-3/8" 60.3mm
60075001	60075002	60075003	60075004	3/4" 19.0mm	1/2" 12.7mm	0.120" 3.1mm	3" 76.2mm
60100001	60100002	60100003	60100004	1" 25.4mm	1/2" 12.7mm	0.120" 3.1mm	3" 76.2mm



## Uniflute® HSS Countersink - Single Flute Series 61 Steam Treated

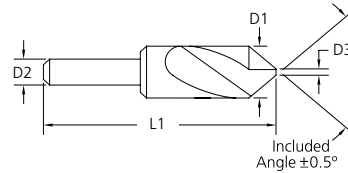
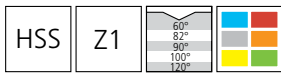

60°	82°	90°	100°	120°	Tool Dimensions			
Tool No.	Tool No.	Tool No.	Tool No.	Tool No.	D1	D2	D3 (Max)	L1
61012501	61012502	61012503	61012504	61012506	1/8" 3.2mm	1/8" 3.2mm	0.030" 0.8mm	1-1/2" 38.1mm
61018701	61018702	61018703	61018704	61018706	3/16" 4.8mm	3/16" 4.8mm	0.045" 1.1mm	1-1/2" 38.1mm
61025001	61025002	61025003	61025004	61025006	1/4" 6.4mm	1/4" 6.4mm	0.045" 1.1mm	2" 50.8mm
61037501	61037502	61037503	61037504	61037506	3/8" 9.5mm	1/4" 6.4mm	0.060" 1.5mm	2" 50.8mm
61050001	61050002	61050003	61050004	61050006	1/2" 12.7mm	1/4" 6.4mm	0.060" 1.5mm	2" 50.8mm
61062501	61062502	61062503	61062504	61062506	5/8" 15.9mm	1/4" 6.4mm	0.060" 1.5mm	2" 50.8mm
61075001	61075002	61075003	61075004	61075006	3/4" 19.0mm	1/2" 12.7mm	0.120" 3.1mm	2-3/4" 69.9mm
61100001	61100002	61100003	61100004	61100006	1" 25.4mm	1/2" 12.7mm	0.120" 3.1mm	2-3/4" 69.9mm
61125001	61125002	61125003	-	-	1-1/4" 31.8mm	1/2" 12.7mm	0.120" 3.1mm	3" 76.2mm
61150001	61150002	61150003	-	-	1-1/2" 38.1mm	3/4" 19.0mm	1/4" 6.4mm	3-1/2" 88.9mm
61200001	61200002	61200003	-	-	2" 50.8mm	3/4" 19.0mm	1/2" 12.7mm	3-3/4" 95.3mm
61250001	61250002	61250003	-	-	2-1/2" 63.5mm	3/4" 19.0mm	3/4" 19.0mm	5" 127.0mm
61300001	61300002	61300003	-	-	3" 76.2mm	3/4" 19.0mm	1" 25.4mm	5-1/4" 133.4mm



## Uniflute® HSS Countersink - Single Flute Series 61B Coated

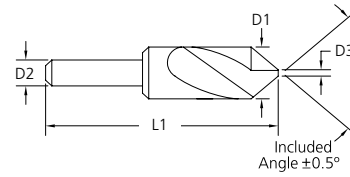
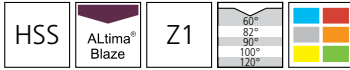

60°	82°	90°	100°	120°	Tool Dimensions			
Tool No.	Tool No.	Tool No.	Tool No.	Tool No.	D1	D2	D3 (Max)	L1
61B012501	61B012502	61B012503	61B012504	61B012506	1/8" 3.2mm	1/8" 3.2mm	0.030" 0.8mm	1-1/2" 38.1mm
61B018701	61B018702	61B018703	61B018704	61B018706	3/16" 4.8mm	3/16" 4.8mm	0.045" 1.1mm	1-1/2" 38.1mm
61B025001	61B025002	61B025003	61B025004	61B025006	1/4" 6.4mm	1/4" 6.4mm	0.045" 1.1mm	2" 50.8mm
61B037501	61B037502	61B037503	61B037504	61B037506	3/8" 9.5mm	1/4" 6.4mm	0.060" 1.5mm	2" 50.8mm
61B050001	61B050002	61B050003	61B050004	61B050006	1/2" 12.7mm	1/4" 6.4mm	0.060" 1.5mm	2" 50.8mm
61B062501	61B062502	61B062503	61B062504	61B062506	5/8" 15.9mm	1/4" 6.4mm	0.060" 1.5mm	2" 50.8mm
61B075001	61B075002	61B075003	61B075004	61B075006	3/4" 19.0mm	1/2" 12.7mm	0.120" 3.1mm	2-3/4" 69.9mm
61B100001	61B100002	61B100003	61B100004	61B100006	1" 25.4mm	1/2" 12.7mm	0.120" 3.1mm	2-3/4" 69.9mm



## Uniflute® HSS Countersink - Single Flute Series 61T Coated

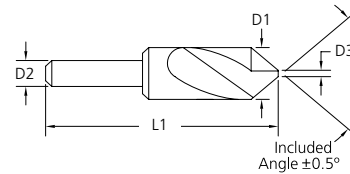
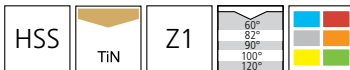

60°	82°	90°	100°	120°	Tool Dimensions			
Tool No.	Tool No.	Tool No.	Tool No.	Tool No.	D1	D2	D3 (Max)	L1
61T012501	61T012502	61T012503	61T012504	61T012506	1/8" 3.2mm	1/8" 3.2mm	0.030" 0.8mm	1-1/2" 38.1mm
61T018701	61T018702	61T018703	61T018704	61T018706	3/16" 4.8mm	3/16" 4.8mm	0.045" 1.1mm	1-1/2" 38.1mm
61T025001	61T025002	61T025003	61T025004	61T025006	1/4" 6.4mm	1/4" 6.4mm	0.045" 1.1mm	2" 50.8mm
61T037501	61T037502	61T037503	61T037504	61T037506	3/8" 9.5mm	1/4" 6.4mm	0.060" 1.5mm	2" 50.8mm
61T050001	61T050002	61T050003	61T050004	61T050006	1/2" 12.7mm	1/4" 6.4mm	0.060" 1.5mm	2" 50.8mm
61T062501	61T062502	61T062503	61T062504	61T062506	5/8" 15.9mm	1/4" 6.4mm	0.060" 1.5mm	2" 50.8mm
61T075001	61T075002	61T075003	61T075004	61T075006	3/4" 19.0mm	1/2" 12.7mm	0.120" 3.1mm	2-3/4" 69.9mm
61T100001	61T100002	61T100003	61T100004	61T100006	1" 25.4mm	1/2" 12.7mm	0.120" 3.1mm	2-3/4" 69.9mm



## Uniflute® HSS Countersink Sets - Single Flute Series 61 Steam Treated

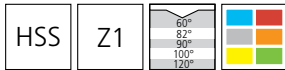

### 4pc Set - Series 61

Set Includes - 1/4" (6.4mm), 1/2" (12.7mm), 3/4" (19.0mm) & 1" (25.4mm)

Set No.	Angle
64100001	60°
64100002	82°
64100003	90°
64100004	100°
64100006	120°

### 7pc Set - Series 61

Set Includes - 3/16" (4.8mm), 1/4" (6.4mm), 3/8" (9.5mm), 1/2" (12.7mm), 5/8" (15.9mm), 3/4" (19.0mm) & 1" (25.4mm)

Set No.	Angle
64100071	60°
64100072	82°
64100073	90°
64100074	100°
64100076	120°



## Series 61T TiN Coated

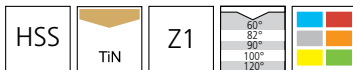

### 4pc Set - Series 61T

Set Includes - 1/4" (6.4mm), 1/2" (12.7mm), 3/4" (19.0mm), 1" (25.4mm)

Set No.	Angle
64T100001	60°
64T100002	82°
64T100003	90°





## Vibration Free Countersink - 6 Flute Series 78 Uncoated

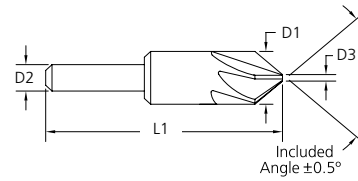

60°	82°	90°	100°	120°	Tool Dimensions			
Tool No.	Tool No.	Tool No.	Tool No.	Tool No.	D1	D2	D3 (Max)	L1
78012501	78012502	78012503	78012504	78012506	1/8" 3.2mm	1/8" 3.2mm	0.030" 0.8mm	1-1/2" 38.1mm
78018701	78018702	78018703	78018704	78018706	3/16" 4.8mm	3/16" 4.8mm	0.045" 1.1mm	1-1/2" 38.1mm
78025001	78025002	78025003	78025004	78025006	1/4" 6.4mm	1/4" 6.4mm	0.060" 1.5mm	2" 50.8mm
78037501	78037502	78037503	78037504	78037506	3/8" 9.5mm	1/4" 6.4mm	0.090" 2.3mm	2" 50.8mm
78050001	78050002	78050003	78050004	78050006	1/2" 12.7mm	3/8" 9.5mm	0.150" 3.8mm	2-1/8" 54.0mm
78062501	78062502	78062503	78062504	78062506	5/8" 15.9mm	3/8" 9.5mm	0.180" 4.6mm	2-3/8" 60.3mm
78075001	78075002	78075003	78075004	78075006	3/4" 19.0mm	1/2" 12.7mm	0.210" 5.3mm	2-3/4" 69.9mm
78100001	78100002	78100003	78100004	78100006	1" 25.4mm	1/2" 12.7mm	1/4" 6.4mm	2-3/4" 69.9mm
78125001	78125002	78125003	-	-	1-1/4" 31.8mm	1/2" 12.7mm	0.370" 9.4mm	3" 76.2mm
78150001	78150002	78150003	-	-	1-1/2" 38.1mm	3/4" 19.0mm	0.430" 10.9mm	3-1/2" 88.9mm



## Vibration Free HSS Countersink - 6 Flute Series 79 Steam Treated

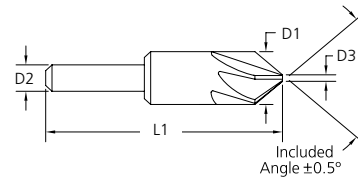
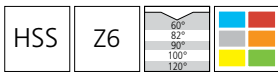

60°	82°	90°	100°	120°	Tool Dimensions			
Tool No.	Tool No.	Tool No.	Tool No.	Tool No.	D1	D2	D3 (Max)	L1
79012501	79012502	79012503	79012504	79012506	1/8" 3.2mm	1/8" 3.2mm	0.030" 0.8mm	1-1/2" 38.1mm
79018701	79018702	79018703	79018704	79018706	3/16" 4.8mm	3/16" 4.8mm	0.045" 1.1mm	1-1/2" 38.1mm
79025001	79025002	79025003	79025004	79025006	1/4" 6.4mm	1/4" 6.4mm	0.060" 1.5mm	2" 50.8mm
79031201	79031202	79031203	79031204	79031206	5/16" 7.9mm	1/4" 6.4mm	0.080" 2.0mm	2" 50.8mm
79037501	79037502	79037503	79037504	79037506	3/8" 9.5mm	1/4" 6.4mm	0.090" 2.3mm	2" 50.8mm
79050001	79050002	79050003	79050004	79050006	1/2" 12.7mm	3/8" 9.5mm	0.150" 3.8mm	2" 50.8mm
79062501	79062502	79062503	79062504	79062506	5/8" 15.9mm	3/8" 9.5mm	0.180" 4.6mm	2-1/4" 57.1mm
79075001	79075002	79075003	79075004	79075006	3/4" 19.0mm	1/2" 12.7mm	0.210" 5.3mm	2-3/4" 69.9mm
79087501	79087502	79087503	79087504	79087506	7/8" 22.2mm	1/2" 12.7mm	0.230" 5.8mm	2-3/4" 69.9mm
79100001	79100002	79100003	79100004	79100006	1" 25.4mm	1/2" 12.7mm	1/4" 6.4mm	2-3/4" 69.9mm
79125001	79125002	79125003	79125004	79125006	1-1/4" 31.8mm	1/2" 12.7mm	0.370" 9.4mm	3" 76.2mm
79150001	79150002	79150003	79150004	79150006	1-1/2" 38.1mm	3/4" 19.0mm	0.430" 10.9mm	3-1/2" 88.9mm
79200001	79200002	79200003	79200004	79200006	2" 50.8mm	3/4" 19.0mm	0.620" 15.7mm	3-3/4" 95.2mm
79250001	79250002	79250003	-	-	2-1/2" 63.5mm	3/4" 19.0mm	3/4" 19.0mm	5" 127.0mm
79300001	79300002	79300003	-	-	3" 76.2mm	3/4" 19.0mm	1" 25.4mm	5-1/4" 133.4mm



## Vibration Free HSS Countersink - 6 Flute Series 79B Coated

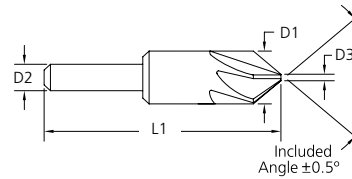
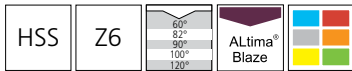

60°	82°	90°	100°	120°	Tool Dimensions			
Tool No.	Tool No.	Tool No.	Tool No.	Tool No.	D1	D2	D3 (Max)	L1
79B012501	79B012502	79B012503	79B012504	79B012506	1/8" 3.2mm	1/8" 3.2mm	0.030" 0.8mm	1-1/2" 38.1mm
79B018701	79B018702	79B018703	79B018704	79B018706	3/16" 4.8mm	3/16" 4.8mm	0.045" 1.1mm	1-1/2" 38.1mm
79B025001	79B025002	79B025003	79B025004	79B025006	1/4" 6.4mm	1/4" 6.4mm	0.060" 1.5mm	2" 50.8mm
79B037501	79B037502	79B037503	79B037504	79B037506	3/8" 9.5mm	1/4" 6.4mm	0.090" 2.3mm	2" 50.8mm
79B050001	79B050002	79B050003	79B050004	79B050006	1/2" 12.7mm	3/8" 9.5mm	0.150" 3.8mm	2" 50.8mm
79B062501	79B062502	79B062503	79B062504	79B062506	5/8" 15.9mm	3/8" 9.5mm	0.180" 4.6mm	2-1/4" 57.1mm
79B075001	79B075002	79B075003	79B075004	79B075006	3/4" 19.0mm	1/2" 12.7mm	0.210" 5.3mm	2-3/4" 69.9mm
79B100001	79B100002	79B100003	79B100004	79B100006	1" 25.4mm	1/2" 12.7mm	1/4" 6.4mm	2-3/4" 69.9mm



## Vibration Free HSS Countersink - 6 Flute Series 79T Coated

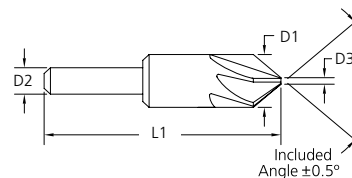
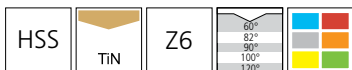

60°	82°	90°	100°	120°	Tool Dimensions			
Tool No.	Tool No.	Tool No.	Tool No.	Tool No.	D1	D2	D3 (Max)	L1
79T012501	79T012502	79T012503	79T012504	79T012506	1/8" 3.2mm	1/8" 3.2mm	0.030" 0.8mm	1-1/2" 38.1mm
79T018701	79T018702	79T018703	79T018704	79T018706	3/16" 4.8mm	3/16" 4.8mm	0.045" 1.1mm	1-1/2" 38.1mm
79T025001	79T025002	79T025003	79T025004	79T025006	1/4" 6.4mm	1/4" 6.4mm	0.060" 1.5mm	2" 50.8mm
79T037501	79T037502	79T037503	79T037504	79T037506	3/8" 9.5mm	1/4" 6.4mm	0.090" 2.3mm	2" 50.8mm
79T050001	79T050002	79T050003	79T050004	79T050006	1/2" 12.7mm	3/8" 9.5mm	0.150" 3.8mm	2" 50.8mm
79T062501	79T062502	79T062503	79T062504	79T062506	5/8" 15.9mm	3/8" 9.5mm	0.180" 4.6mm	2-1/4" 57.1mm
79T075001	79T075002	79T075003	79T075004	79T075006	3/4" 19.0mm	1/2" 12.7mm	0.210" 5.3mm	2-3/4" 69.9mm
79T100001	79T100002	79T100003	79T100004	79T100006	1" 25.4mm	1/2" 12.7mm	1/4" 6.4mm	2-3/4" 69.9mm



## Vibration Free HSS Countersink - 6 Flute Sets Series 79 Steam Treated



### 4pc Set - Series 79

Set Includes - 1/4" (6.4mm), 1/2" (12.7mm)  
3/4" (19.0mm), 1" (25.4mm)

Set No.	Angle
79000011	60°
79000012	82°
79000013	90°
79000014	100°

### 7pc Set - Series 79

Set Includes - 1/4" (6.4mm), 5/16" (7.9mm), 3/8" (9.5mm)  
1/2" (12.7mm), 5/8" (15.9mm), 3/4" (19.0mm), 1" (25.4mm)

Set No.	Angle
79000001	60°
79000002	82°
79000003	90°
79000004	100°



## Vibration Free HSS Countersink - 6 Flute Set Series 79T Coated

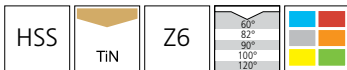

### 4pc Set - Series 79T

Set Includes - 1/4" (6.4mm), 1/2" (12.7mm)  
3/4" (19.0mm), 1" (25.4mm)

Set No.	Angle
79T000011	60°
79T000012	82°
79T000013	90°



FORDMAX  
Countersinks  
Fraises  
Senker  
Svasatori  
Pogłębiacze

## HSS Aircraft Countersink - 3 Flute Series 92 Bright Finish

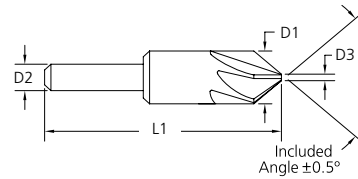
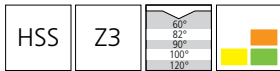

60°	82°	90°	100°	120°	Tool Dimensions			
Tool No.	Tool No.	Tool No.	Tool No.	Tool No.	D1	D2	D3 (Max)	L1
92025001	92025002	92025003	92025004	92025006	1/4" 6.4mm	1/4" 6.4mm	0.070" 1.8mm	1-1/4" 31.8mm
92037501	92037502	92037503	92037504	92037506	3/8" 9.5mm	1/4" 6.4mm	0.110" 2.8mm	1-5/8" 41.3mm
92050001	92050002	92050003	92050004	92050006	1/2" 12.7mm	1/4" 6.4mm	0.150" 3.8mm	2" 50.8mm
92062501	92062502	92062503	92062504	92062506	5/8" 15.9mm	1/4" 6.4mm	0.190" 4.8mm	2-1/4" 57.1mm
92075001	92075002	92075003	92075004	92075006	3/4" 19.0mm	1/2" 12.7mm	0.230" 5.8mm	3" 76.2mm
92087501	92087502	92087503	92087504	92087506	7/8" 22.2mm	1/2" 12.7mm	0.260" 6.6mm	3" 76.2mm
92100001	92100002	92100003	92100004	92100006	1" 25.4mm	1/2" 12.7mm	0.300" 7.6mm	3-1/4" 82.5mm
92112501	92112502	92112503	92112504	92112506	1-1/8" 28.6mm	1/2" 12.7mm	0.340" 8.6mm	3-1/4" 82.5mm
92125001	92125002	92125003	92125004	92125006	1-1/4" 31.8mm	5/8" 15.9mm	0.380" 9.6mm	3-1/2" 88.9mm
92150001	92150002	92150003	92150004	92150006	1-1/2" 38.1mm	3/4" 19.0mm	0.450" 11.4mm	3-7/8" 98.4mm
92200001	92200002	92200003	92200004	92200006	2" 50.8mm	3/4" 19.0mm	0.600" 15.2mm	4-1/4" 107.9mm



## HSS Aircraft Countersink Set - 3 Flute Series 92 Bright Finish

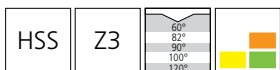

Countersinks  
 Fraises  
 Senker  
 Svasatori  
 Pogłębiacze

5pc Set - Series 92	
Set Includes - 1/4" (6.4mm), 3/8" (9.5mm), 1/2" (12.7mm), 5/8" (15.9mm) & 3/4" (19.0mm)	
Set No.	Angle
92000011	60°
92000012	82°
92000013	90°
92000014	100°
92000016	120°



## HSS Countersink - 3 Flute Series 893T Coated

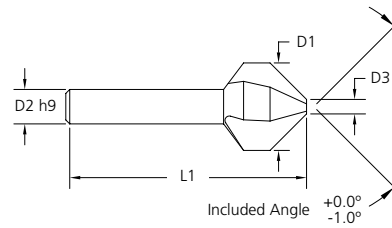

90°	Tool Dimensions				
Tool No.	Fastner Size	D1	D2	D3 (Max)	L1
893 0430T	M2	4.3	4.0	1.3	40.0
893 0500T	M2.5	5.0	4.0	1.5	40.0
893 0600T	M3	6.0	5.0	1.5	45.0
893 0630T	M3	6.3	5.0	1.5	45.0
893 0700T	M3.5	7.0	6.0	1.8	50.0
893 0800T	M4	8.0	6.0	2.0	50.0
893 0830T	M4	8.3	6.0	2.0	50.0
893 1000T	M5	10.0	6.0	2.5	50.0
893 1040T	M5	10.4	6.0	2.5	50.0
893 1150T	M6	11.5	8.0	2.8	56.0
893 1240T	M6	12.4	8.0	2.8	56.0
893 1500T	M8	15.0	10.0	3.2	60.0
893 1650T	M8	16.5	10.0	3.2	60.0
883 1900T	M10	19.0	10.0	3.5	63.0
893 2050T	M10	20.5	10.0	3.5	63.0
893 2300T	M12	23.0	10.0	3.8	67.0
893 2500T	M12	25.0	10.0	3.8	67.0
893 3100T	M16	31.0	12.0	4.2	71.0



## HSS Countersink Set - 3 Flute Series 893T

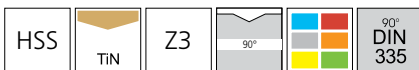

6pc Set - Series 893T	
Set Includes - 6.3mm, 8.3mm, 10.4mm 12.4mm, 16.5mm & 20.5mm	
Set No.	Angle
893T 6PC 90 DEG	90°



Countersinks  
Fraises  
Senker  
Svasatori  
Pogłębiacze

## HSS & Carbide Countersinks

### Uniflute® Countersink Feed Rates

Uniflute® countersinks are designed with cam relief, therefore feed rates should not exceed 0.125mm per revolution on larger diameter holes. Reduced feeds are recommended for smaller diameter holes. A controlled feed results in vibration-free finishes associated with Uniflute® countersinks.

### Multiple Flute Countersink Feed Rates

Multiple flute countersinks are designed for increased feed rates. Because there is more than one cutting edge, tooth loads are not excessive so vibration can be controlled, allowing higher feedrates.

### Speeds

To determine optimum speed, start at the lower end of the cutting speed range shown in the chart below, increasing the speed until performance is maximized. When a countersink is operated at excessive RPM, vibration may result and the cutting edges can overheat and become prematurely worn.

Workpiece Material Group		Material Type	Vc (m/min)			
			HSS	HSS TiN Coated	HSS ALtima® Blaze Coated	Carbide
Steels	P	Low Carbon	25 - 30	30 - 40	40 - 50	40 - 50
		Medium Carbon	20 - 25	25 - 30	35 - 40	35 - 45
		Alloy Steels	15 - 20	20 - 25	25 - 30	20 - 30
Stainless Steels	M	Free Machining	10 - 25	10 - 30	15 - 40	25 - 40
		Difficult Stainless	5 - 10	5 - 20	10 - 25	15 - 25
Special Alloys	S	High Temperature Alloys	5 - 8	5 - 10	5 - 10	8 - 15
		Titanium Alloys	15 - 20	20 - 25	25 - 30	20 - 30
Cast Irons	K	Cast Iron	15 - 30	20 - 40	25 - 50	30 - 55
		Malleable Iron	25 - 30	30 - 35	40 - 45	30 - 45
Hardened Steels	H	45 - 50 HRc	5 - 10	5 - 10	8 - 10	8 - 15
		50 - 55 HRc	2 - 5	3 - 5	5 - 10	5 - 10
Non Ferrous	N	Aluminium Alloys	45 - 75	60 - 100	75 - 120	90 - 150
		Brass / Bronze	25 - 40	30 - 50	35 - 60	45 - 80

#### Conversion Formula

$$\text{RPM} = \text{Vc (m/min)} \times 318.0 \div \text{Countersink } \varnothing *$$

\* Countersink  $\varnothing$  Must Be Calculated in mm  
 (When making the calculation, use the diameter on the countersink where the cutting is actually taking place)

## HSS & Carbide Countersinks

### Minimum Body Diameter for 90° Flat Head Cap Screws (mm)

Cap Screw Size (mm)	Countersink Diameter (mm)
M3	7.0
M4	10.0
M5	12.0
M6	14.0
M8	19.0
M10	23.0
M12	25.0
M16	31.0

### Size Diameter Gain for every 0.025mm of Axial Depth in to a Pre-Drilled Hole

Included Angle	Axial Depth (mm)	Diameter Gain (mm)
30°	0.025	0.0127
45°	0.025	0.0203
60°	0.025	0.0254
82°	0.025	0.0432
90°	0.025	0.0508
100°	0.025	0.0711
120°	0.025	0.0864

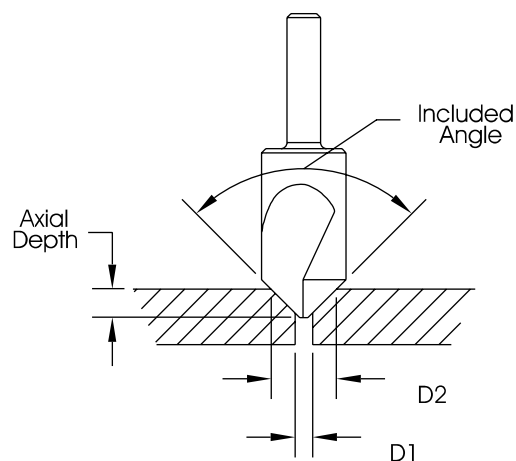

$$\text{DIAMETER GAIN} = D2 - D1$$



## HSS & Carbide Countersinks

All M.A.Ford® HSS countersinks are heat treated in an electronically controlled vacuum furnace. This assures precise hardening and eliminates the possibility of decarburization. All heat treating is done in our own facilities for maximum control and assurance of desired hardness and toughness.

Most M.A.Ford® HSS countersinks receive an additional heat treat process known as the Steam Homogeneous Process. This process is like a final tempering, relieving internal grinding stresses. The result is a much tougher cutting edge that stays sharper, longer. Additionally, the Steam Homogeneous Process provides a tough, hard, porous oxide film on the tool that is sufficient enough to retain cutting oil, further reducing frictional heat and extending tool life.

### Coated Countersinks



### Coating Properties

	TiN	ALtima® Blaze
Micro Hardness (HV)	2300	3200
Max. Working Temperature	600° C 1112° F	1100° C 2012° F
Friction Coefficient	0.40	0.35

#### ALtima® Blaze

features high temperature hardness and oxidation resistance that provides extreme wear resistance under all machining conditions.

#### TiN

provides a higher surface hardness and increased lubricity over an uncoated tool.





For aggressive cutting action, smooth operation and long tool life, M.A.Ford® Edgehog® carbide burrs are by far the most effective solution for even the most demanding de-burring and pre-finishing applications. With more than 160 different tool shapes and sizes available in our Edgehog range, including cylindrical, conical, ball and countersink styles, there's a burr to meet virtually every application.

(FR)

“Pour les actions de coupe agressives, un bon fonctionnement et une longue durée de vie de l’outil, les fraises en carbure M.A.Ford® Edgehog® sont de loin la solution la plus efficace pour les applications d’ébavurage et de pré-finition même les plus exigeantes. Avec plus de 160 différentes formes et tailles d’outils disponibles dans notre gamme Edgehog, incluant les formes de fraises cylindriques, coniques, ronds: il existe un outil d’ébavurage pour pratiquement n’importe quel type d’application.”

(DE)

Bei sehr intensiven Schnitvorgängen und für eine reibungslose Funktion sowie lange Werkzeugstandzeiten stellen die Edgehog®-Hartmetallentgrater von M.A.Ford® bei Weitem die effektivste Lösung sogar bei den anspruchsvollsten Entgratungs- und Nachbearbeitungsanwendungen dar. Unser Edgehog-Sortiment umfasst mehr als 160 verschiedene Werkzeugformen und -größen, einschließlich zylindrische, konische, kugelförmige sowie Senker-Formen, und daher steht für nahezu jede Anwendung ein Entgrater zur Verfügung.

(IT)

Per un taglio aggressivo ma scorrevole ed una lunga vita utensile, le lime rotative in metallo duro M.A.Ford® Edgehog® sono certamente la soluzione più efficace, anche per le operazioni di sbavatura e pre-finitura più impegnative. Con più di 160 utensili di diverse geometrie (tra cui cilindriche, coniche, sferiche e tipo svasatore) e misure disponibili, nella gamma Edgehog c'è la lima rotative idonea per qualsiasi applicazione.

(PL)

Piłniki obrotowe z węglika M.A.Ford® Edgehog® umożliwiają pracę w wymagających warunkach przy zachowaniu długiej żywotności narzędzia. Są zdecydowanie najbardziej efektywnym rozwiązaniem dla najbardziej wymagających operacji szlifowania. W naszej ofercie M.A.Ford® Edgehog® znajduje się ponad 160 narzędzi o różnych średnicach i kształtach (cylindryczne, kulowe, stożkowe).

# Edgehog®

## Carbide Burrs

Fraise Lime Rotative Carbure Hartmetall-Frässtifte  
Lime rotative in MD Zadziorzy

	Page
<b>Edgehog® Carbide Burrs</b> Series SA	210
<b>Edgehog® Carbide Burrs</b> Series SB	211
<b>Edgehog® Carbide Burrs</b> Series SC	212
<b>Edgehog® Carbide Burrs</b> Series SD	213
<b>Edgehog® Carbide Burrs</b> Series SE	214
<b>Edgehog® Carbide Burrs</b> Series SF	215
<b>Edgehog® Carbide Burrs</b> Series SG	216
<b>Edgehog® Carbide Burrs</b> Series SH	217
<b>Edgehog® Carbide Burrs</b> Series SJ	218
<b>Edgehog® Carbide Burrs</b> Series SK	219
<b>Edgehog® Carbide Burrs</b> Series SL	220
<b>Edgehog® Carbide Burrs</b> Series SM	221
<b>Edgehog® Carbide Burrs</b> Series SN	222
<b>Technical Information</b>	223 - 224



FORDMAX

Burrs  
Fraises Limes  
Frässtifte  
Lime Rotative  
Zadziorzy

## Edgehog® Carbide Burrs Series SA

**Type A**

Cylinder

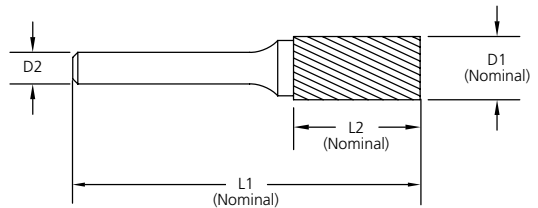

### 3mm Shank Burrs



Standard Cut Tool No.	Alt Diamond Tool No.	Fine Cut Tool No.	Shear Cut Tool No.	Tool Dimensions			
				D1	D2	L1	L2
SA-41M	SA-41M-D	SA-41M-F	-	1.6	3.0	38.0	6.0
SA-42M	SA-42M-D	SA-42M-F	-	2.4	3.0	38.0	11.1
SA-43M	SA-43M-D	SA-43M-F	-	3.0	3.0	38.0	14.3
SA-52M	SA-52M-D	SA-52M-F	-	4.0	3.0	38.0	12.7
SA-53M	SA-53M-D	SA-53M-F	-	4.8	3.0	38.0	12.7
SA-51M	SA-51M-D	SA-51M-F	-	6.4	3.0	51.0	12.7

### 6mm Shank Burrs



Standard Cut Tool No.	Alt Diamond Tool No.	Fine Cut Tool No.	Shear Cut Tool No.	Tool Dimensions			
				D1	D2	L1	L2
SA-11M	SA-11M-D	-	-	3.0	6.0	50.0	12.7
SA-13M	-	-	-	4.0	6.0	50.0	16.0
-	SA-14M-D	-	-	4.8	6.0	50.0	16.0
SA-1M	SA-1M-D	SA-1M-F	-	6.0	6.0	50.0	16.0
SA-2M	SA-2M-D	-	-	8.0	6.0	64.0	19.0
SA-3M	SA-3M-D	SA-3M-F	SA-3NFM	9.5	6.0	64.0	19.0
SA-3MZ	SA-3MZ-D	SA-3MZ-F	-	10.0	6.0	65.0	20.0
SA-4M	SA-4M-D	-	-	11.0	6.0	70.0	25.0
SA-5MZ	SA-5MZ-D	-	-	12.0	6.0	70.0	25.0
SA-5M	SA-5M-D	SA-5M-F	SA-5NFM	12.7	6.0	70.0	25.0
SA-6M	SA-6M-D	SA-6M-F	SA-6NFM	16.0	6.0	70.0	25.0
SA-15M	-	-	-	19.0	6.0	58.0	12.7
SA-7M	SA-7M-D	SA-7M-F	-	19.0	6.0	70.0	25.0
SA-9M	SA-9M-D	SA-9M-F	-	25.0	6.0	70.0	25.0



### 3mm Shank Burrs



Standard Cut Tool No.	Alt Diamond Tool No.	Fine Cut Tool No.	Shear Cut Tool No.	Tool Dimensions			
				D1	D2	L1	L2
SA-43L76M	SA-43L76M-D	-	-	3.0	3.0	76.0	14.3

Note: Burrs 12.0mm and above are available with an 8.0mm shank on request as a non-stock standard.



# Edgehog® Carbide Burrs Series SB



Type B

Cylinder - With End Cut

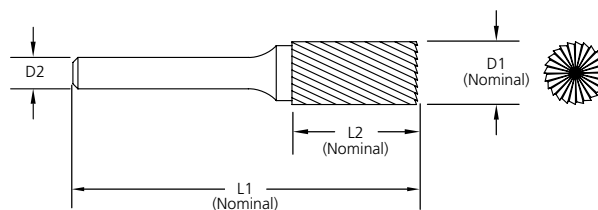

## 3mm Shank Burrs



Standard Cut Tool No.	Alt Diamond Tool No.	Fine Cut Tool No.	Shear Cut Tool No.	Tool Dimensions			
				D1	D2	L1	L2
SB-51M	SB-51M-D	SB-51M-F	-	6.4	3.0	43.0	4.8

## 6mm Shank Burrs



Standard Cut Tool No.	Alt Diamond Tool No.	Fine Cut Tool No.	Shear Cut Tool No.	Tool Dimensions			
				D1	D2	L1	L2
SB-11M	SB-11M-D	-	-	3.0	6.0	50.0	12.7
SB-13M	SB-13M-D	-	-	4.0	6.0	50.0	16.0
-	SB-14M-D	-	-	4.8	6.0	50.0	16.0
SB-1M	SB-1M-D	SB-1M-F	-	6.0	6.0	50.0	16.0
SB-2M	SB-2M-D	SB-2M-F	-	8.0	6.0	64.0	19.0
SB-3M	SB-3M-D	SB-3M-F	SB-3NFM	9.5	6.0	64.0	19.0
SB-3MZ	SB-3MZ-D	SB-3MZ-F	-	10.0	6.0	65.0	20.0
SB-4M	SB-4M-D	-	-	11.0	6.0	70.0	25.0
SB-5MZ	SB-5MZ-D	SB-5MZ-F	-	12.0	6.0	70.0	25.0
SB-5M	SB-5M-D	-	SB-5NFM	12.7	6.0	70.0	25.0
SB-6M	SB-6M-D	-	-	16.0	6.0	70.0	25.0
-	SB-16M-D	-	-	19.0	6.0	64.0	19.0
-	SB-7M-D	SB-7M-F	-	19.0	6.0	70.0	25.0
SB-9M	SB-9M-D	-	-	25.0	6.0	70.0	25.0

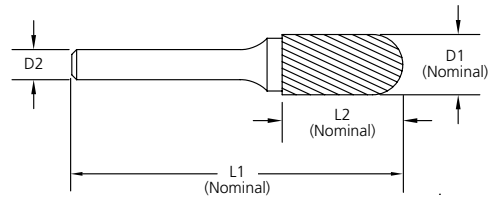

# Edgehog® Carbide Burrs Series SC

**Type C**
**Ball Nosed Cylinder**

## 3mm Shank Burrs

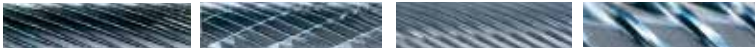

Standard Cut Tool No.	Alt Diamond Tool No.	Fine Cut Tool No.	Shear Cut Tool No.	Tool Dimensions			
				D1	D2	L1	L2
SC-41M	SC-41M-D	SC-41M-F	-	2.4	3.0	38.0	11.1
SC-42M	SC-42M-D	SC-42M-F	-	3.0	3.0	38.0	14.3
SC-52M	SC-52M-D	SC-52M-F	-	4.0	3.0	38.0	12.7
SC-53M	SC-53M-D	SC-53M-F	-	4.8	3.0	38.0	12.7
SC-51M	SC-51M-D	SC-51M-F	-	6.4	3.0	51.0	12.7

## 6mm Shank Burrs



Standard Cut Tool No.	Alt Diamond Tool No.	Fine Cut Tool No.	Shear Cut Tool No.	Tool Dimensions			
				D1	D2	L1	L2
-	SC-11M-D	-	-	3.0	6.0	50.0	12.7
SC-13M	SC-13M-D	-	-	4.0	6.0	50.0	16.0
SC-14M	SC-14M-D	-	-	4.8	6.0	50.0	16.0
SC-1M	SC-1M-D	SC-1M-F	-	6.0	6.0	50.0	16.0
SC-2M	SC-2M-D	SC-2M-F	-	8.0	6.0	64.0	19.0
SC-3M	SC-3M-D	SC-3M-F	SC-3NFM	9.5	6.0	64.0	19.0
SC-3MZ	SC-3MZ-D	SC-3MZ-F	-	10.0	6.0	65.0	20.0
SC-4M	SC-4M-D	-	-	11.0	6.0	70.0	25.0
SC-5MZ	SC-5MZ-D	SC-5MZ-F	-	12.0	6.0	70.0	25.0
SC-5M	SC-5M-D	SC-5M-F	SC-5NFM	12.7	6.0	70.0	25.0
SC-6M	SC-6M-D	SC-6M-F	SC-6NFM	16.0	6.0	70.0	25.0
SC-7M	SC-7M-D	-	-	19.0	6.0	70.0	25.0
SC-9M	SC-9M-D	-	-	25.0	6.0	70.0	25.0



## 3mm Shank Burrs



Standard Cut Tool No.	Alt Diamond Tool No.	Fine Cut Tool No.	Shear Cut Tool No.	Tool Dimensions			
				D1	D2	L1	L2
SC-42L76M	SC-42L76M-D	-	-	3.0	3.0	76.0	14.3



## 6mm Shank Burrs



Standard Cut Tool No.	Alt Diamond Tool No.	Fine Cut Tool No.	Shear Cut Tool No.	Tool Dimensions			
				D1	D2	L1	L2
SC-1L6M	-	-	-	6.0	6.0	166.0	16.0
SC-3L6M	-	-	-	9.5	6.0	169.0	19.0
SC-5L6M	SC-5L6M-D	SC-5L6M-F	-	12.7	6.0	175.0	25.0

Note: Burrs 12.0mm and above are available with an 8.0mm shank on request as a non-stock standard.



# Edgehog® Carbide Burrs Series SD



Type D

Ball

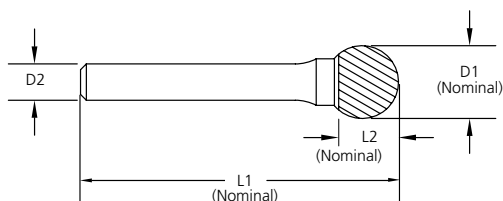

## 3mm Shank Burrs



Standard Cut Tool No.	Alt Diamond Tool No.	Fine Cut Tool No.	Shear Cut Tool No.	Tool Dimensions			
				D1	D2	L1	L2
SD-41M	SD-41M-D	SD-41M-F	-	2.4	3.0	38.0	2.0
SD-42M	SD-42M-D	SD-42M-F	-	3.0	3.0	38.0	2.8
SD-53M	SD-53M-D	SD-53M-F	-	4.8	3.0	38.0	4.0
SD-51M	SD-51M-D	SD-51M-F	-	6.4	3.0	44.0	5.6

## 6mm Shank Burrs



Standard Cut Tool No.	Alt Diamond Tool No.	Fine Cut Tool No.	Shear Cut Tool No.	Tool Dimensions			
				D1	D2	L1	L2
SD-11M	SD-11M-D	-	-	3.0	6.0	50.0	2.8
SD-14M	SD-14M-D	SD-14M-F	-	4.8	6.0	50.0	4.0
SD-1M	SD-1M-D	SD-1M-F	-	6.0	6.0	50.0	5.0
SD-2M	SD-2M-D	-	-	8.0	6.0	51.0	6.0
SD-3M	SD-3M-D	SD-3M-F	SD-3NFM	9.5	6.0	53.0	7.0
SD-3MZ	SD-3MZ-D	SD-3MZ-F	-	10.0	6.0	54.0	7.0
SD-4M	SD-4M-D	SD-4M-F	-	11.0	6.0	54.0	8.0
SD-5MZ	-	-	-	12.0	6.0	56.0	9.5
SD-5M	SD-5M-D	SD-5M-F	SD-5NFM	12.7	6.0	56.0	10.0
SD-6M	SD-6M-D	SD-6M-F	SD-6NFM	16.0	6.0	59.0	13.0
SD-7M	SD-7M-D	-	-	19.0	6.0	62.0	16.0
SD-9M	SD-9M-D	-	-	25.0	6.0	68.0	21.0



## 3mm Shank Burrs



Standard Cut Tool No.	Alt Diamond Tool No.	Fine Cut Tool No.	Shear Cut Tool No.	Tool Dimensions			
				D1	D2	L1	L2
SD-42L76M	SD-42L76M-D	-	-	3.0	3.0	76.0	2.8



## 6mm Shank Burrs



Standard Cut Tool No.	Alt Diamond Tool No.	Fine Cut Tool No.	Shear Cut Tool No.	Tool Dimensions			
				D1	D2	L1	L2
-	SD-1L6M-D	-	-	6.0	6.0	155.0	5.0
-	SD-2L6M-D	-	-	8.0	6.0	159.0	6.0
SD-3L6M	SD-3L6M-D	SD-3L6M-F	-	9.5	6.0	161.0	7.0
SD-5L6M	SD-5L6M-D	SD-5L6M-F	-	12.7	6.0	164.0	10.0

Note: Burrs 12.0mm and above are available with an 8.0mm shank on request as a non-stock standard.

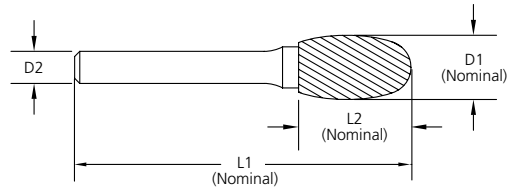

# Edgehog® Carbide Burrs Series SE

**Type E**
**Oval**

## 3mm Shank Burrs

				Tool Dimensions			
Standard Cut Tool No.	Alt Diamond Tool No.	Fine Cut Tool No.	Shear Cut Tool No.	D1	D2	L1	L2
SE-41M	SE-41M-D	SE-41M-F	-	3.0	3.0	38.0	5.6
SE-53M	SE-53M-D	-	-	4.8	3.0	38.0	7.0
SE-51M	SE-51M-D	SE-51M-F	-	6.4	3.0	48.0	9.5

## 6mm Shank Burrs

				Tool Dimensions			
Standard Cut Tool No.	Alt Diamond Tool No.	Fine Cut Tool No.	Shear Cut Tool No.	D1	D2	L1	L2
SE-1M	SE-1M-D	-	-	6.0	6.0	50.0	9.5
-	SE-2M-D	-	-	8.0	6.0	60.0	16.0
SE-3M	SE-3M-D	SE-3M-F	SE-3NFM	9.5	6.0	60.0	16.0
SE-5M	SE-5M-D	SE-5M-F	SE-5NFM	12.7	6.0	67.0	22.0
SE-6M	SE-6M-D	-	SE-6NFM	16.0	6.0	70.0	25.0
SE-7M	SE-7M-D	-	-	19.0	6.0	70.0	25.0



## 3mm Shank Burrs

				Tool Dimensions			
Standard Cut Tool No.	Alt Diamond Tool No.	Fine Cut Tool No.	Shear Cut Tool No.	D1	D2	L1	L2
SE-41L76M	-	-	-	3.0	3.0	76.0	5.6



## 6mm Shank Burrs

				Tool Dimensions			
Standard Cut Tool No.	Alt Diamond Tool No.	Fine Cut Tool No.	Shear Cut Tool No.	D1	D2	L1	L2
SE-3L6M	SE-3L6M-D	-	-	9.5	6.0	166.0	16.0
SE-5L6M	SE-5L6M-D	-	-	12.7	6.0	172.0	22.0

Note: Burrs 12.0mm and above are available with an 8.0mm shank on request as a non-stock standard.





# Edgehog® Carbide Burrs Series SF



Type  
**F**

Ball Nosed Tree

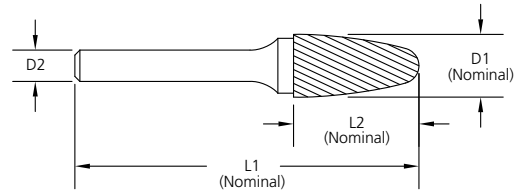

## 3mm Shank Burrs

				Tool Dimensions			
Standard Cut Tool No.	Alt Diamond Tool No.	Fine Cut Tool No.	Shear Cut Tool No.	D1	D2	L1	L2
SF-41M	SF-41M-D	SF-41M-F	-	3.0	3.0	38.0	6.0
SF-42M	SF-42M-D	SF-42M-F	-	3.0	3.0	38.0	12.7
SF-53M	SF-53M-D	SF-53M-F	-	4.8	3.0	38.0	12.7
SF-51M	SF-51M-D	SF-51M-F	-	6.4	3.0	51.0	12.7

## 6mm Shank Burrs

				Tool Dimensions			
Standard Cut Tool No.	Alt Diamond Tool No.	Standard Cut Tool No.	Alt Diamond Tool No.	D1	D2	L1	L2
SF-11M	SF-11M-D	SF-11M-F	-	3.0	6.0	50.0	12.7
SF-1M	SF-1M-D	SF-1M-F	-	6.0	6.0	50.0	16.0
SF-3M	SF-3M-D	-	SF-3NFM	9.5	6.0	64.0	19.0
SF-4M	SF-4M-D	-	-	11.0	6.0	70.0	25.0
SF-5MZ	SF-5MZ-D	SF-5MZ-F	-	12.0	6.0	70.0	25.0
SF-13M	SF-13M-D	SF-13M-F	-	12.7	6.0	64.0	19.0
SF-5M	SF-5M-D	SF-5M-F	SF-5NFM	12.7	6.0	70.0	25.0
SF-6M	SF-6M-D	SF-6M-F	SF-6NFM	16.0	6.0	70.0	25.0
SF-7M	SF-7M-D	SF-7M-F	-	19.0	6.0	70.0	25.0
SF-14M	SF-14M-D	-	-	19.0	6.0	76.0	31.0



## 3mm Shank Burrs

				Tool Dimensions			
Standard Cut Tool No.	Alt Diamond Tool No.	Fine Cut Tool No.	Shear Cut Tool No.	D1	D2	L1	L2
SF-42L76M	SF-42L76M-D	-	-	3.0	3.0	76.0	12.7



## 6mm Shank Burrs

				Tool Dimensions			
Standard Cut Tool No.	Alt Diamond Tool No.	Fine Cut Tool No.	Shear Cut Tool No.	D1	D2	L1	L2
SF-1L6M	SF-1L6M-D	SF-1L6M-F	-	6.0	6.0	166.0	16.0
SF-3L6M	SF-3L6M-D	-	-	9.5	6.0	169.0	19.0
SF-5L6M	SF-5L6M-D	-	-	12.7	6.0	175.0	25.0

Note: Burrs 12.0mm and above are available with an 8.0mm shank on request as a non-stock standard.



# Edgehog® Carbide Burrs Series SG

**Type G**

Tree

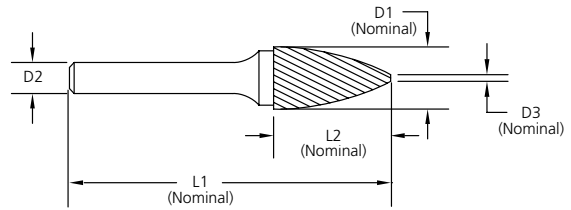

## 3mm Shank Burrs

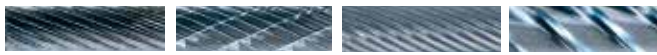

Standard Cut Tool No.	Alt Diamond Tool No.	Fine Cut Tool No.	Shear Cut Tool No.
SG-41M	SG-41M-D	SG-41M-F	-
SG-42M	SG-42M-D	SG-42M-F	-
SG-43M	SG-43M-D	SG-43M-F	-
SG-53M	SG-53M-D	SG-53M-F	-
SG-51M	SG-51M-D	SG-51M-F	-

Tool Dimensions				
D1	D2	L1	L2	D3
3.0	3.0	38.0	6.0	0.46
3.0	3.0	38.0	8.0	0.46
3.0	3.0	38.0	9.5	0.46
4.8	3.0	38.0	12.7	0.64
6.4	3.0	51.0	12.7	0.76

## 6mm Shank Burrs

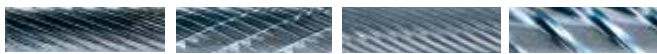

Standard Cut Tool No.	Alt Diamond Tool No.	Fine Cut Tool No.	Shear Cut Tool No.
SG-1M	SG-1M-D	SG-1M-F	-
SG-2M	SG-2M-D	SG-2M-F	-
SG-3M	SG-3M-D	SG-3M-F	-
SG-3MZ	SG-3MZ-D	SG-3MZ-F	-
SG-5MZ	SG-5MZ-D	SG-5MZ-F	-
SG-13M	SG-13M-D	SG-13M-F	-
SG-5M	SG-5M-D	SG-5M-F	-
SG-6M	SG-6M-D	SG-6M-F	-
SG-7M	SG-7M-D	SG-7M-F	-
SG-15M	SG-15M-D	SG-15M-F	-

Tool Dimensions				
D1	D2	L1	L2	D3
6.0	6.0	50.0	16.0	0.76
8.0	6.0	64.0	19.0	1.02
9.5	6.0	64.0	19.0	1.02
10.0	6.0	65.0	20.0	1.14
12.0	6.0	70.0	25.0	1.27
12.7	6.0	64.0	19.0	1.27
12.7	6.0	70.0	25.0	1.27
16.0	6.0	70.0	25.0	1.27
19.0	6.0	70.0	25.0	1.27
19.0	6.0	84.0	38.0	1.78



## 3mm Shank Burrs



Standard Cut Tool No.	Alt Diamond Tool No.	Fine Cut Tool No.	Shear Cut Tool No.
SG-42L76M	SG-42L76M-D	-	-
SG-43L76M	SG-43L76M-D	-	-

Tool Dimensions				
D1	D2	L1	L2	D3
3.0	3.0	76.0	8.0	0.46
3.0	3.0	76.0	9.5	0.46



## 6mm Shank Burrs



Standard Cut Tool No.	Alt Diamond Tool No.	Fine Cut Tool No.	Shear Cut Tool No.
SG-1L6M	SG-1L6M-D	SG-1L6M-F	-
-	SG-3L6M-D	SG-3L6M-F	-
-	SG-5L6M-D	SG-5L6M-F	-

Tool Dimensions				
D1	D2	L1	L2	D3
6.0	6.0	166.0	16.0	0.76
9.5	6.0	169.0	19.0	1.02
12.7	6.0	175.0	25.0	1.27

Note: Burrs 12.0mm and above are available with an 8.0mm shank on request as a non-stock standard.





# Edgehog® Carbide Burrs Series SH



Type H

Flame

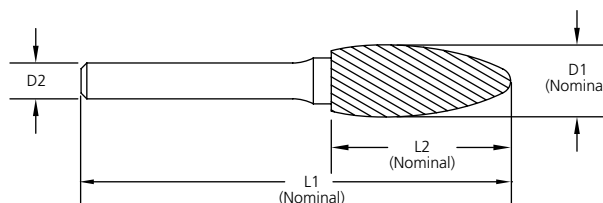

## 3mm Shank Burrs

				Tool Dimensions			
Standard Cut Tool No.	Alt Diamond Tool No.	Fine Cut Tool No.	Shear Cut Tool No.	D1	D2	L1	L2
SH-41M	SH-41M-D	SH-41M-F	-	3.0	3.0	38.0	6.0
SH-53M	SH-53M-D	SH-53M-F	-	4.8	3.0	38.0	9.5

## 6mm Shank Burrs

				Tool Dimensions			
Standard Cut Tool No.	Alt Diamond Tool No.	Fine Cut Tool No.	Shear Cut Tool No.	D1	D2	L1	L2
SH-1M	SH-1M-D	SH-1M-F	-	6.0	6.0	50.0	16.0
SH-2M	SH-2M-D	SH-2M-F	-	8.0	6.0	64.0	19.0
SH-5M	SH-5M-D	SH-5M-F	-	12.7	6.0	76.0	31.0
SH-6M	SH-6M-D	SH-6M-F	-	16.0	6.0	81.0	36.0
SH-7M	SH-7M-D	SH-7M-F	-	19.0	6.0	86.0	41.0



## 3mm Shank Burrs

				Tool Dimensions			
Standard Cut Tool No.	Alt Diamond Tool No.	Fine Cut Tool No.	Shear Cut Tool No.	D1	D2	L1	L2
SH-41L76M	SH-41L76M-D	-	-	3.0	3.0	76.0	6.0



## 6mm Shank Burrs

				Tool Dimensions			
Standard Cut Tool No.	Alt Diamond Tool No.	Standard Cut Tool No.	Alt Diamond Tool No.	D1	D2	L1	L2
SH-2L6M	SH-2L6M-D	SH-2L6M-F	-	8.0	6.0	169.0	19.0
SH-5L6M	SH-5L6M-D	SH-5L6M-F	-	12.7	6.0	181.0	31.0

Note: Burrs 12.0mm and above are available with an 8.0mm shank on request as a non-stock standard.



FORDMAX

Burrs  
Fraises Limes  
Frässtifte  
Lime Rotative  
Zadzioy

# Edgehog® Carbide Burrs Series SJ

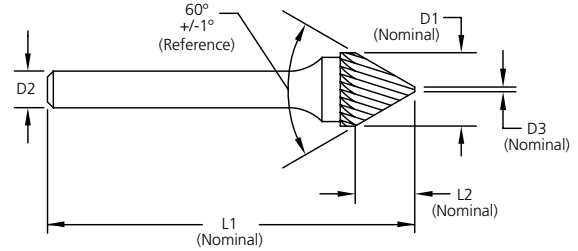
**Type J**
**Countersink 60°**

## 3mm Shank Burrs



Standard Cut Tool No.	Alt Diamond Tool No.	Fine Cut Tool No.	Shear Cut Tool No.	Tool Dimensions			
				D1	D2	L1	L2
SJ-42M	SJ-42M-D	SJ-42M-F	-	3.0	3.0	38.0	2.4
-	SJ-82M-D*	-	-	3.0	3.0	38.0	2.4

\* SJ-82M-D is double ended

## 6mm Shank Burrs



Standard Cut Tool No.	Alt Diamond Tool No.	Fine Cut Tool No.	Shear Cut Tool No.	Tool Dimensions			
				D1	D2	L1	L2
SJ-1M	SJ-1M-D	-	-	6.0	6.0	50.0	4.8
SJ-3M	SJ-3M-D	-	-	9.5	6.0	55.0	8.0
SJ-5M	SJ-5M-D	-	-	12.7	6.0	58.0	11.0
SJ-6M	SJ-6M-D	-	-	16.0	6.0	62.0	12.7
SJ-7M	SJ-7M-D	-	-	19.0	6.0	64.0	14.0
SJ-9M	SJ-9M-D	-	-	25.0	6.0	70.0	21.0

Note: Burrs 12.0mm and above are available with an 8.0mm shank on request as a non-stock standard.

**FORDMAX**

 Burrs  
 Fraises Limes  
 Frässtifte  
 Lime Rotative  
 Zadziozy

# Edgehog® Carbide Burrs Series SK



Type  
**K**

Countersink 90°

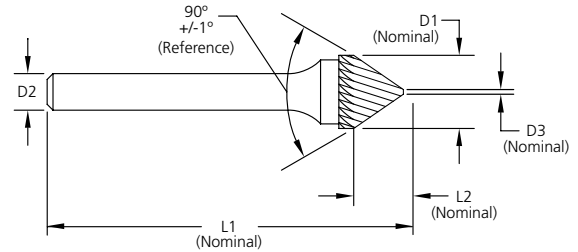

## 3mm Shank Burrs



Standard Cut Tool No.	Alt Diamond Tool No.	Fine Cut Tool No.	Shear Cut Tool No.	Tool Dimensions			
				D1	D2	L1	L2
SK-42M	SK-42M-D	-	-	3.0	3.0	38.0	1.6
SK-82M*	SK-82M-D*	-	-	3.0	3.0	38.0	1.6

\* SK-82M is double ended

## 6mm Shank Burrs



Standard Cut Tool No.	Alt Diamond Tool No.	Fine Cut Tool No.	Shear Cut Tool No.	Tool Dimensions			
				D1	D2	L1	L2
SK-1M	SK-1M-D	-	-	6.0	6.0	50.0	3.0
SK-3M	SK-3M-D	-	-	9.5	6.0	52.0	4.8
SK-5M	SK-5M-D	-	-	12.7	6.0	53.0	6.4
SK-6M	SK-6M-D	-	-	16.0	6.0	56.0	8.0
SK-7M	SK-7M-D	-	-	19.0	6.0	58.0	9.5
SK-9M	SK-9M-D	-	-	25.0	6.0	61.0	12.7

Note: Burrs 12.0mm and above are available with an 8.0mm shank on request as a non-stock standard.



**FORDMAX**

Burrs  
Fraises Limes  
Frässtifte  
Lime Rotative  
Zadziorzy

## Edgehog® Carbide Burrs Series SL

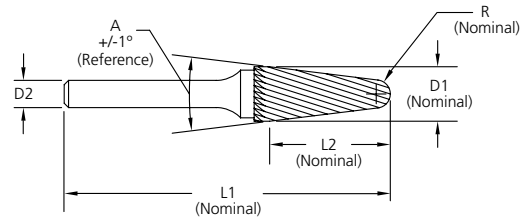

**Type L**
**Ball Nosed Cone**

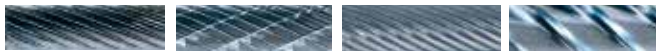
### 3mm Shank Burrs

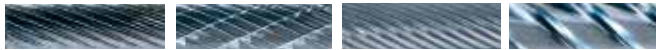

				Tool Dimensions				
Standard Cut Tool No.	Alt Diamond Tool No.	Fine Cut Tool No.	Shear Cut Tool No.	D1	D2	L1	L2	A°
SL-41M	SL-41M-D	SL-41M-F	-	3.0	3.0	38.0	9.5	8°
SL-42M	SL-42M-D	SL-42M-F	-	3.0	3.0	38.0	12.7	8°
SL-53M	SL-53M-D	SL-53M-F	-	4.8	3.0	38.0	12.7	14°

### 6mm Shank Burrs



				Tool Dimensions				
Standard Cut Tool No.	Alt Diamond Tool No.	Fine Cut Tool No.	Shear Cut Tool No.	D1	D2	L1	L2	A°
SL-1M	SL-1M-D	SL-1M-F	-	6.0	6.0	50.0	16.0	14°
SL-2M	SL-2M-D	SL-2M-F	-	8.0	6.0	71.0	24.0	14°
SL-3M	SL-3M-D	SL-3M-F	SL-3NFM	9.5	6.0	75.0	28.0	14°
SL-4M	SL-4M-D	SL-4M-F	SL-4NFM	12.7	6.0	76.0	30.0	14°
-	SL-6M-D	SL-6M-F	SL-6NFM	16.0	6.0	80.0	33.0	14°
SL-7M	SL-7M-D	SL-7M-F	-	19.0	6.0	86.0	39.0	14°



### 3mm Shank Burrs



				Tool Dimensions				
Standard Cut Tool No.	Alt Diamond Tool No.	Fine Cut Tool No.	Shear Cut Tool No.	D1	D2	L1	L2	A°
SL-42L76M	SL-42L76M-D	-	-	3.0	3.0	76.0	12.7	8°



### 6mm Shank Burrs



				Tool Dimensions				
Standard Cut Tool No.	Alt Diamond Tool No.	Fine Cut Tool No.	Shear Cut Tool No.	D1	D2	L1	L2	A°
-	-	SL-2L6M-F	-	8.0	6.0	176.0	24.0	14°
SL-3L6M	SL-3L6M-D	SL-3L6M-F	-	9.5	6.0	180.0	28.0	14°
SL-4L6M	SL-4L6M-D	SL-4L6M-F	-	12.7	6.0	182.0	30.0	14°

Note: Burrs 12.0mm and above are available with an 8.0mm shank on request as a non-stock standard.



# Edgehog® Carbide Burrs Series SM



Type M

Cone

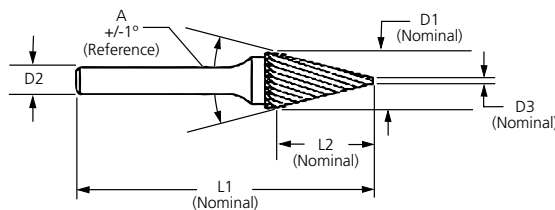

## 3mm Shank Burrs

Standard Cut Tool No.	Alt Diamond Tool No.	Fine Cut Tool No.	Shear Cut Tool No.
SM-45M	SM-45M-D	SM-45M-F	-
SM-41M	SM-41M-D	SM-41M-F	-
SM-42M	SM-42M-D	SM-42M-F	-
SM-43M	SM-43M-D	SM-43M-F	-
SM-53M	SM-53M-D	SM-53M-F	-
SM-51M	SM-51M-D	SM-51M-F	-

Tool Dimensions					
D1	D2	L1	L2	A°	D <sup>3</sup>
3.0	3.0	38.0	4.8	32°	0.46
3.0	3.0	38.0	9.5	12°	1.09
3.0	3.0	38.0	11.1	14°	0.36
3.0	3.0	38.0	16.0	7°	1.14
4.8	3.0	38.0	12.7	16°	0.97
6.4	3.0	54.0	12.7	22°	1.32

## 6mm Shank Burrs

Standard Cut Tool No.	Alt Diamond Tool No.	Fine Cut Tool No.	Shear Cut Tool No.
SM-1M	SM-1M-D	SM-1M-F	-
SM-2M	SM-2M-D	SM-2M-F	-
SM-3M	SM-3M-D	SM-3M-F	-
SM-4M	SM-4M-D	SM-4M-F	-
SM-5M	SM-5M-D	SM-5M-F	-
SM-6M	SM-6M-D	SM-6M-F	-

Tool Dimensions					
D1	D2	L1	L2	A°	D <sup>3</sup>
6.0	6.0	50.0	12.7	22°	1.17
6.0	6.0	50.0	19.0	14°	1.42
6.0	6.0	50.0	25.0	10°	1.65
9.5	6.0	63.0	16.0	28°	1.32
12.7	6.0	69.0	22.0	28°	1.32
16.0	6.0	72.0	25.0	31°	1.52



## 3mm Shank Burrs

Standard Cut Tool No.	Alt Diamond Tool No.	Fine Cut Tool No.	Shear Cut Tool No.
SM-42L76M	SM-42L76M-D	-	-

Tool Dimensions					
D1	D2	L1	L2	A°	D <sup>3</sup>
3.0	3.0	76.0	11.0	14°	0.36

Note: Burrs 12.0mm and above are available with an 8.0mm shank on request as a non-stock standard.



## Edgehog® Carbide Burrs Series SN

**Type N**

Inverted Cone

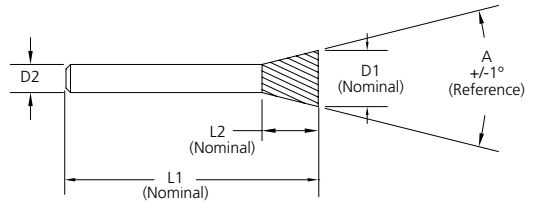

### 3mm Shank Burrs

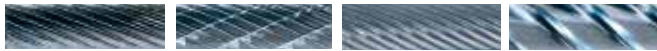

				Tool Dimensions				
Standard Cut Tool No.	Alt Diamond Tool No.	Fine Cut Tool No.	Shear Cut Tool No.	D1	D2	L1	L2	A°
SN-41M	SN-41M-D	SN-41M-F	-	2.4	3.0	38.0	3.0	10°
SN-42M	SN-42M-D	SN-42M-F	-	3.0	3.0	38.0	4.8	10°
SN-53M	SN-53M-D	SN-53M-F	-	4.8	3.0	38.0	6.4	10°
SN-51M	SN-51M-D	SN-51M-F	-	6.4	3.0	44.0	6.4	10°

### 6mm Shank Burrs



				Tool Dimensions				
Standard Cut Tool No.	Alt Diamond Tool No.	Fine Cut Tool No.	Shear Cut Tool No.	D1	D2	L1	L2	A°
-	SN-1M-D	SN-1M-F	-	6.0	6.0	50.0	8.0	10°
SN-2M	SN-2M-D	SN-2M-F	-	9.5	6.0	55.0	9.5	13°
SN-4M	SN-4M-D	SN-4M-F	-	12.7	6.0	58.0	12.7	28°
SN-6M	SN-6M-D	SN-6M-F	-	16.0	6.0	64.0	19.0	18°
-	SN-7M-D	SN-7M-F	-	19.0	6.0	61.0	16.0	30°

**FORDMAX**

 Burrs  
 Fraises Limes  
 Frässtifte  
 Lime Rotative  
 Zadziozy

## Edgehog® Carbide Burrs

### Burr Fluting Chart Tableau de denture par fraise

Tabelle der Fräuserschneiden | Numero di taglienti

Tabela pilników obrotowych

Number Of Flutes ( ± 10% )			
Burr Ø	Standard Cut	Fine Cut	Shear Cut
1.6	10	12	-
2.0	10	12	-
2.4	12	16	-
3.0	12	20	-
4.0	14	24	-
4.8	15	24	-
6.0	16	25	-
8.0	18	30	-
9.5	20	30	6
11.0	22	30	-
12.7	24	35	8*
16.0	26	40	8**
19.0	30	40	-
25.0	35	45	-

\* Except SL-4NFM - 6 Flutes

\*\* Except SD-6NFM, SE-6NFM and SF-6NFM - 10 Flutes.

Alternate Diamond Grind - LH Fluting 40% of RH Fluting

Diamond Grind - LH Fluting 80% of RH Fluting.

### Recommended Operating Speeds

Vitesse d'utilisation recommandées | Empfohlene Betriebsdrehzahlen

Velocità di utilizzo consigliate | Zalecane prędkości pracy

Burr Diameter Ø mm	Operating Speed RPM	
	From	To
3.0	45,000	90,000
6.0	23,000	45,000
9.5	19,000	30,000
12.7	15,000	22,000
16.0	12,000	18,000
19.0	7,500	15,000

The speed guidelines above are general recommendations.

Speeds may require adjusting based on material and application.

### Burr Application By Material Type de denture de fraises par matière | Frästift-Anwendungsgebiete nach Material

Scelta dell'utensile in funzione del materiale | Zastosowanie frezu (pilnika obrotowego) według materiału

Material	Standard Cut	Alt Diamond Cut	Fine Cut	Shear Cut
Aluminium	•	•	-	•
Brass, Bronze, Copper	•	•	-	-
Carbon	•	-	-	-
Cast Iron	•	-	-	-
Fibreglass	•	-	-	-
Hard Rubber	•	-	-	•
Magnesium	-	-	-	•
Masonite	•	-	-	•
Plastics	•	-	-	•
Steels - 40-60HRc	•	•	•	-
Steels, Alloy Steels	•	•	-	-
Nickel/Chrome Steels	•	•	-	-
Stainless Steels	•	•	•	-
Steel Weldments	•	•	-	-
Titanium	•	•	-	-
Wood	-	-	-	•
Zinc	-	-	-	•

## Edgehog® Carbide Burrs

### Problems and Solutions | Problèmes et Solutions | Probleme und Lösungen | Problemi e Soluzioni | Problemy i Rozwiązania

#### Possible Causes | Causes Possibles | Mögliche Ursachen | Cause Possibili | Możliwe Przyczyny

Problem	Possible Causes   Causes Possibles   Mögliche Ursachen   Cause Possibili   Możliwe Przyczyny									
	Excessive Force	Shank Friction With Workpiece	Worn Burr	Incorrect Collet Location	Worn Grinder Bearings	Poor Shank Straightness	Unstable Workpiece	Working in Soft Materials	Cutting Abrasive Material	Low Setup Rigidity
Broken Brazed Joint	●	●	●	-	-	-	-	-	-	-
Poor Burr Control	-	-	-	●	●	●	●	-	-	●
Flutes Clogging	-	-	-	-	-	-	-	●	-	-
Excessive Vibration	-	-	-	●	●	●	●	-	-	●
Poor Finish	-	-	-	●	●	●	●	●	-	●
Poor Tool Life	-	●	-	●	●	●	●	-	●	●

#### Possible Causes | Causes Possibles | Mögliche Ursachen | Cause Possibili | Możliwe Przyczyny

Problem	Possible Causes   Causes Possibles   Mögliche Ursachen   Cause Possibili   Możliwe Przyczyny							
	Reduce Cutting Pressure	Ensure Shank / Workpiece Clearance	Replace Worn Burr	Check Burr Location & Replace Collet if Necessary	Check & Replace Grinder Bearings if Necessary	Check Shank Straightness - Replace Burr if Necessary	Improve Workpiece Stability	Use a Coarser Cut Burr
Broken Brazed Joint	●	●	●	-	-	-	-	-
Poor Burr Control	-	-	-	●	●	●	●	-
Flutes Clogging	-	-	-	-	-	-	-	●
Excessive Vibration	-	-	-	●	●	●	●	-
Poor Finish	-	-	-	●	●	●	●	-
Poor Tool Life	-	●	-	●	●	●	-	-

#### Possible Causes | Causes Possibles | Mögliche Ursachen | Cause Possibili | Możliwe Przyczyny

Problem	Possible Causes   Causes Possibles   Mögliche Ursachen   Cause Possibili   Możliwe Przyczyny						
	Use Lubricant or Anti-Sticking Agent	Increase RPM	Reduce RPM	Make Lighter Cuts	Change to a Finer Cut Burr	Faster Feed	Slower Feed
Broken Brazed Joint	-	-	-	-	-	-	-
Poor Burr Control	-	-	-	-	-	-	-
Flutes Clogging	●	●	●	●	-	-	-
Excessive Vibration	-	●	●	-	-	●	●
Poor Finish	-	●	●	-	●	●	●
Poor Tool Life	●	-	●	-	●	●	●



**SHAVIV**  
Soluzioni per la sbavatura

**vargus**  
NEUMO Ehrenberg Group

Novità

**SHAVIV**  
**GENIUS™**  
Tool selector per  
sbavatori a mano  
[www.shaviv-genius.com](http://www.shaviv-genius.com)

Il tocco finale  
per la finitura



# SHAVIV by VARGUS

La Società VARGUS, fondata nel 1960, ha sviluppato, prodotto e distribuito in tutto il mondo utensili da taglio e di finitura per l'industria meccanica e della plastica. E' parte del Gruppo NEUMO Ehrenberg, una organizzazione multinazionale con sede in Germania. La nostra organizzazione internazionale serve i clienti in oltre 100 nazioni nel mondo ed è specializzata in tre prodotti: SHAVIV sbavatori manuali di finitura, VARDEX frese a filettare e GROOVEX utensili per gole e svasature.



Guarda

## Completa gamma di soluzioni per la sbavatura con manici SHAVIV ergonomici

### **mango II** Lavorazioni a lunga distanza

Il manico più raccomandato per comfort e controllo sulla sbavatura

Mango II - Lavora con tutti i supporti e tutte le lame.

Semplice dispositivo di supporto. Manico ergonomico confortevole per mani di dimensioni medie.



Mango II Manico Codice nr.: 152-00019

### **mango II B/E** Lavorazioni a distanza ravvicinata

Il manico più raccomandato per comfort e controllo sulla sbavatura

Mango II B/E - Lavora con tutte le lame di tipo B e E.

Dispositivo permanente di sicurezza per la sostituzione delle lame.

Manico ergonomico confortevole per mani di dimensioni medie.



B10

Manico Mango II B Codice nr.: 152-00009



E100

Manico Mango II E Codice nr.: 152-00016

### **mango Click** Distanza ravvicinata

Mango Click E

Mango Click - La sbavatura non è mai stata così semplice!

Porta tutte le lame di tipo E. Facile da usare, confortevole e di lunga durata.

Indicato per mani di grandi dimensioni.



E100

Manico Mango Click E Codice nr.: 152-00013

### **Manico Classico A**

Manico universale. Accetta tutte le lame e tutti i supporti. Per conservare le lame nel manico svitare semplicemente il cappuccio posteriore.



Codice nr.: 152-00003

### **Manico A (In Alluminio)**

Manico universale per applicazioni gravose, versione in alluminio. Porta tutte le lame e tutti i supporti.



Codice nr.: 152-00005

### **Manico 1**

Manico non telescopico, eccellente nelle applicazioni gravose. Porta tutte le lame di tipo E.



Codice nr.: 152-00026

### **Manico Universale HC1 (Handy Chuck)**

Può portare piccole punte, maschi, alesatori, lime, spazzole ed altri oggetti di diametro variabile tra 1 mm. e 8 mm. Può essere impiegato con le lame C50 e C60. Utile per riparare o montare orologi, apparecchiature elettriche ed elettroniche in miniatura.



Codice nr.: 155-29057

# mango II Set per accesso remoto



The **Finishing Touch**

Mango IIB Distanza ravvicinata

Mango IIE Distanza ravvicinata

Mango II Accesso remoto

## Il manico più raccomandato per comfort e controllo della sbavatura

- Porta tutti i supporti SHAVIV (vedere pag. 17)
- Meccanismo di supporto semplice
- Impugnatura confortevole ed ergonomica per mani di dimensioni medie



Manico Mango II per accesso remoto

Codice nr.:152-00019

### Mango II Set B Modello Base

Il set più popolare per la sbavatura di fori, scanalature e spigoli. Monta tutte le lame di tipo B. Le lame possono essere inserite sia in senso longitudinale che perpendicolare.



Spigoli lineari



Spigoli esterni

B10

B

B20

Set	Manico	Supporto	Lama	Codice nr.
Mango II Set B	Mango II	B	B10,B20	155-90056

### Mango II Set E Per Applicazioni Gravose

Per impieghi gravosi su fori, chiavette e spigoli. Monta tutte le lame di tipo E.



Spigoli lineari



Spigoli esterni



Spigoli interni ed esterni fori passanti

E200

E300

Set	Manico	Supporto	Lama	Codice nr.
Mango II Set E	Mango II	E	E100,E200, E300	155-90065

### Mango II Set D Per Lamierini

Combinazione perfetta per la sbavatura di lamierini sino a 3 mm di spessore. La lama elimina le bave su entrambi i lati in una singola passata.



D80C

D



Superficie piana



Lamierini

Per maggiore sicurezza se ne consiglia l'utilizzo con il salvamano, Codice nr.: 152-00030

Set	Manico	Supporto	Lama	Codice nr.
Mango II Set D	Mango II	D	D80C	155-90064
Shaviv Set D	Classico	D	D80C	155-29068

### Mango II Set C Per Raschiatura

Disegnato per raschiature di grande precisione; è composto da lame triangolari con 3 taglianti. Il supporto telescopico permette di raggiungere le zone più inaccessibili. La chiave in dotazione permette di smontare le lame in sicurezza.



C42

C



Spigoli lineari



Spigoli esterni



Superficie piana



Pareti interne

Set	Manico	Supporto	Lama	Codice nr.
Mango II Set C	Mango II	C	C42	155-90062

### Mango II Set FR

#### Ratchet Burr per diametri interni (ID)

E' dotato di un supporto FR con arpionismo di non ritorno, ideale quando la sbavatura in rotazione diventa impossibile per motivi di ingombro. Svasatura per diametri interni (ID) fino a 20 mm.



F20

FR



Spigoli esterni

Set	Manico	Supporto	Lama	Codice nr.
Mango II Set FR	Mango II	FR	F20	155-90072
Shaviv Set FR	Classico	FR	F20	155-29071
Set FR Alluminio	Alluminio	FR	F20	155-00223

### Mango II Set F Lo Svasatore

Svasatore resistente per la svasatura e la sbavatura dei fori. Utilizzare sugli spigoli esterni fino a 20 mm di diametro.



F20

F



Spigoli esterni

Set	Manico	Supporto	Lama	Codice nr.
Mango II Set F	Mango II	F	F20	155-90071
Shaviv Set F	Classico	F	F20	155-29070
Set F Alluminio	Alluminio	F	F20	155-00222



# mango II Accesso remoto e set speciali



## Mango II Set M\* 2 in 1

Sbava fori, chiavette e spigoli. Il supporto M porta le lame sia di tipo B sia di tipo E.



Spigoli lineari

Spigoli esterni

Spigoli interni ed esterni fori passanti



Set	Manico	Supporto	Lama	Codice nr.
Mango II Set M	Mango II	M	B10, B20, B30, E100, E111, E200	155-00199
Shaviv Set M	Classico	M	B10, B20, B30, E100, E111, E200	155-29178

## Mango II Set U

Raschiatura di finitura contiene tre tipi differenti di raschietti ed un supporto per operazioni lineari estremamente precise. Ideale per stampisti.



Superfici piane

Pareti interne



Set	Manico	Supporto	Lama	Codice nr.
Mango II Set U	Mango II	U	U1 (BUS1) U31 (BUS31) U4 (BUS4)	155-00221
Shaviv Set U	Classico	U	U1 (BUS1) U31 (BUS31) U4 (BUS4)	155-29119

## Mango II Set G Sbavatura di Chiavette

Ideale per la sbavatura di spigoli e chiavette. Le lame hanno 8 spigoli taglienti e sbavano chiavette esterne o interne fino ad una larghezza di 15 mm.



Spigoli lineari per chiavette



Set	Manico	Supporto	Lama	Codice nr.
Mango II Set G	Mango II	G	G10	155-90074
Shaviv Set G	Classico	G	G10	155-29072

## Mango II Set L

Sbavatura esterna di diametri. Concepito per la sbavatura esterna di tubi e cilindri.



Spigoli lineari

Spigoli tondi



Set	Manico	Supporto	Lama	Codice nr.
Mango II Set L	Mango II	L	L10	155-00220
Shaviv ExcaliBurr Set L	Classico	L	L10	155-29076

## Mango II Set Burr-Ex Ratchet-Burr per Diametri Esterni (OD)

E' dotato di un supporto FR con arpionismo di non ritorno, ideale quando la sbavatura in rotazione diventa impossibile per motivi di ingombro. Svasatura per diametri esterni (OD) fino a 20 mm. In svasatura fino a 26 mm.



Spigoli tondi

Set	Manico	Supporto	Lama	Codice nr.
Mango II Set FRX	Mango II	FR	F26X	155-90073
Shaviv Set FRX	Classico	FR	F26X	155-29146
Set F Alluminio	Alluminio	FR	F26X	155-00224

## Mango II Set Burr-Bi\* Per impieghi gravosi su lamiera - Sbavatura di lamiera

Per materiali di difficile lavorazione con uno o due spigoli lineari sino ad uno spessore di 14 mm. Il supporto porta due lame R10, R20 o R30 per la finitura sagomata dei pezzi sino a 16 mm di spessore. Il set include anche il salvamano per una lavorazione senza problemi.



R10

Lato A per materiali a truciolo lungo

Lato B per materiali a truciolo corto



Lamierini

Spigoli lineari



Set	Manico	Supporto	Lama	Chiave	Codice nr.
Mango II Set Burr-Bi	Mango II	BR	R10 x 2	BR	155-00206
Shaviv Set Burr-Bi	Classico	BR	R10 x 2	BR	155-29140



# mango II Set per lavorazioni a distanza ravvicinata e Bonus Pack

Il manico più raccomandato per comfort e controllo della sbavatura

- Lavora con tutte le lame di tipo B e E
- Adattatore permanente per la sostituzione semplice delle lame
- Impugnatura confortevole ed ergonomica per mani di dimensioni medie



Manico Mango IIB 152-00009

Manico Mango IIE 152-00016

## Set Mango IIB Con lame di tipo B per lavorazioni standard

## Set Mango IIE Con lame di tipo E per lavorazioni gravose



Tutti i set contengono un manico per lavorazioni a distanza ravvicinata Mango IIE e una serie di lame per materiali a truciolo lungo e corto. Per sbavare acciaio, alluminio, rame, ottone, ghisa, acciai inossidabili e plastica.



Per la sbavatura di acciaio, alluminio, rame, ottone, ghisa e plastiche



### Mango IIB+1



B10

### Mango IIB+2



B20

B10

### Mango IIB+4



B20

B25

B11

B10

### Mango IIE+1



E100

### Mango IIE+3



E300

E200

E100

### Mango IIE+5



E300

E200

E100

E111

E120

Set	Manico	Lama	Codice nr.
Mango IIB + 1	Mango IIB	B10	155-90058
Mango IIB + 2	Mango IIB	B10, B20	155-90060
Mango IIB + 4	Mango IIB	B10, B11, B20, B25	155-90061

Set	Manico	Lama	Codice nr.
Mango IIE + 1	Mango IIE	E100	155-90066
Mango IIE + 3	Mango IIE	E100, E200, E300	155-90068
Mango IIE + 5	Mango IIE	E100, E111, E120, E200, E300	155-00162

## Per lavorazioni a distanza ravvicinata

Ogni Bonus Pack comprende 10 lame. Il manico Mango II B/E è **GRATIS**. Disponibile con lame B10 o E100 in HSS o al cobalto

## Per lavorazioni a lunga distanza

Ogni Bonus Pack comprende 10 lame + supporto. Il manico Mango II è **GRATIS**. Disponibile con lame B10 o E100 in HSS o al cobalto



**Manico GRATIS**

HSS 10 X B10  
HSS 10 X E100  
Cobalto 10 X B10  
Cobalto 10 X E100

- I bonus pack contengono una confezione da 10 lame per il loro facile impiego
- Le lame al cobalto garantiscono una lunga durata utile e sono la soluzione ottimale per materiali come l'acciaio inossidabile



Codice nr.	Bonus Pack
155-00177	10 x B10 (HSS)
155-00178	10 x E100 (HSS)
155-00183	10 x B10S (Cobalto)
155-00179	10 x E100S (Cobalto)

Codice nr.	Bonus Pack
155-00180	10 x B10 (HSS) + Supporto B
155-00181	10 x E100 (HSS) + Supporto E
155-00184	10 x B10S (Cobalto) + Supporto B
155-00182	10 x E100S (Cobalto) + Supporto E

# Prodotti

## Kit Premium

I Kit Premium contengono i set e le lame più tradizionali per le applicazioni più frequenti. Ora sono disponibili 7 modelli!

- Ogni kit è concepito per una applicazione specifica
- Bella confezione ergonomica

### Sbavatura e raschiatura

Applicazioni standard



Contiene: manico Mango II, supporto B, supporto C, B10, B20, B30, B60, B11, B70, C40, chiave C  
154-00034

### Sbavatura e raschiatura

Applicazioni gravose



Contiene: manico Mango II, supporto E, supporto C, C42, E100P, E111, E200, E300, E600, E700, chiave C  
154-00036

### Sbavatura e lucidatura



Contiene: manico Mango II, supporto B, supporto E, B10, B11, B25, E111, E250, E400, E707 e utensile Cera-Burr con lama in ceramica  
154-00040

### Sbavatura e svasatura



Contiene: manico Mango II, supporto E, supporto F, E100S, E111, E200, E300, E601, F20, F26X  
154-00033

### Limatura e sbavatura



Contiene: manico MB2020E, 5 lime differenti rivestite in diamante, E100S, E400  
154-00030

### Sbavatura e pulitura di lamierini



Contiene: manico Mango II, supporto D, supporto E, D80C, D82C, E100, E111, E200, E300, E700  
154-00035

## Rivestimento TIN

Per Materiali Esotici

Contiene:  
Lama B: B10P, B11P, B20P, B30P  
Lama E: E100P, E111P, E200P, E300P  
Supporti B, E  
Manico Alluminio  
154-00045



## AEROBURR Set

### Set di sbavatura per aviazione, industria aerospaziale e medicale

Applicazioni standard

#### Set B11P



Manico Mango II  
Supporto B  
5 X B11P rivestite TiN  
155-00231

Applicazioni gravose

#### Set E111P



Manico Mango II  
Supporto E  
5 X E111P rivestite TiN  
155-00232



- Particolarmente concepito per applicazioni nell'industria aeronautica, eccellente anche nell'elettronica e nel medicale
- Per la sbavatura di curve e piccoli fori (1,5 mm)
- Le lame sono rivestite Tin (nitruro di titanio) per la sbavatura di diversi materiali quali acciaio, alluminio, rame, acciaio inossidabile e plastica
- Il rivestimento TIN garantisce una durata utile pari a cinque volte quella delle lame standard non rivestite
- Trova ottima applicazione nel settore degli stampi, dell'automobile e nella R&S



# Prodotti

## Shaviv set flessibili serie Golden

Novità

### Set B flessibile serie Golden

Per sbavatura standard

Contenuto:

- Manico Alluminio
- Supporto per lame serie B
- 5 differenti coppie di lame rivestite TIN  
Multi proposta serie lame B :  
B10P x 2 pezzi, B11P x 2 pezzi,  
B12P x 2 pezzi; B20P x 2 pezzi;  
B30P x 2 pezzi



155-00258

### Set E flessibile serie Golden

Per sbavatura gravosa

Contenuto:

- Manico Alluminio
- Supporto per lame serie E
- 5 differenti coppie di lame rivestite TIN  
Multi proposta serie lame E :  
E100P x 2 pezzi, E110P x 2 pezzi,  
E111P x 2 pezzi; E200P x 2 pezzi;  
E300P x 2 pezzi



155-00259

## Kit di svasatura

L'ultimo kit per la svasatura e la sbavatura.

Utilizzare uno svasatore con un porta inserto (Codice nr. 156-0003) da 1/4" oppure un utensile ad aria. Angolo dell'elica 90°. Ogni kit contiene 3 svasatori in HSS di differenti misure per svasare un'ampia gamma di fori e di materiali. L'inserto di finitura è **GRATIS**.



154-00031



154-00032



### Kit di svasatura a tre eliche

Utensile	Per fori sino a Ø mm	Per fori sino a Ø in
FC20	20mm	13/16"
FC16	16mm	5/8"
FC12	12mm	1/2"
<b>GRATIS</b>	Inserto di finitura con 1 lama B12	



### Kit di svasatura senza elica

Utensile	Gamma fori Ø mm	Gamma fori Ø in
FD20	7-20mm	9/32"-13/16"
FD13	5-13mm	3/16"-1/2"
FD08	2-8mm	5/64"-5/16"
<b>GRATIS</b>	Inserto di finitura con 1 lama B12	

## Nuovo svasatore a 3 eliche

Shaviv, il popolare svasatore a 3 eliche, oggi può essere acquistato singolarmente!



FC20 151-00139

FC16 151-00137

FC12 151-00138



Shaviv, il popolare svasatore a 3 eliche, può essere utilizzato sia sul supporto da 1/4" porta inserto (codice nr.: 156-0003) sia su ogni altro strumento.

## Raschietti rotanti triangolari di alta precisione

- Raschietti rotanti triangolari di alta precisione
- Adatti per utensili ad aria con elevato numero di giri
- In HSS, resistenti ma flessibili
- Eccellenti nella lavorazione di materiali quali metalli, ceramica e plastica
- Impiegati in aviazione, elettronica, gioielleria, stampi ecc

Lama	Diametro gambo	Angolo al vertice	Codice nr.
C81-3	3.0 mm	5°	151-00129
C82-3	3.0 mm	10°	151-00130





## La sbavatura non è mai stata così semplice!

- Lavora con le lame di tipo E, basta un click!
- Facile da usare, comodo con lunga durata utile
- Particolarmente indicato per mani di grandi dimensioni



Mango Click Manico E 152-00013

## Mango Click + 12 E100



**mango**  
Basta un click!



155-29229

Semplice da usare, basta un click. Per mani di grandi dimensioni.

### Mango Click Set E5

**mango**  
Basta un click!



Set	Manico	Lama	Codice nr.
Mango Click Set E5	Mango Click E	E100, E111, E120, E200, E300	155-00161

### Mango Click Set E3

**mango**  
Basta un click!

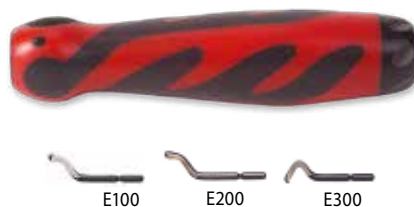

Set	Manico	Lama	Codice nr.
Mango Click Set E3	Mango Click E	E100, E200, E300	155-90076

## Inserti di finitura

### Set Finishing Bit

Utensile di finitura combina il cacciavite portainsero il supporto e l'insero.



**Tipo D**

**Guida: esagonale 1/4"**  
**DIN 3126-C6, 3**  
**ISO 1173**

Bit con lama per sbavare inserito in un supporto da 1/4". Utensile ideale per uso industriale, per elettricisti, idraulici, installatori e per il bricolage.

Set Finishing Bit x: 1 cacciavite per l'insero  
1 finishing-bit



Set	Manico	Lama	Codice nr.
Set Finishing Bit	Cacciavite per l'insero	Finishing Bit	156-00003

### Confezione da 4 Finishing Bit

Una nuova generazione di bit a finire.

- Bit con lama per sbavare
  - Inserito in un supporto da 1/4"
  - Tipo D
- Guida: esagonale 1/4"  
DIN 3126-C6, 3, ISO 1173

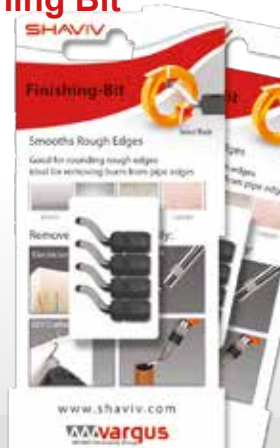

Set	Lama	Codice nr.
Confezione da 4 Finishing Bit	4 Finishing Bit	156-00001



# Set Classico



## Set B\* Modello base

Il set più popolare per la sbavatura di fori, scanalature e spigoli. Monta tutte le lame di tipo B. Le lame possono essere inserite sia in senso longitudinale che perpendicolare.

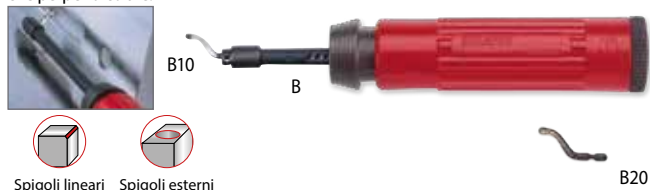

Set	Manico	Supporto	Lama	Codice nr.
Shaviv Set B	Manico Classico A	B	B10, B20	155-29065

## Set E\* Per applicazioni gravose

Per impieghi gravosi su fori, chiavette e spigoli. Porta tutte le lame di tipo E.

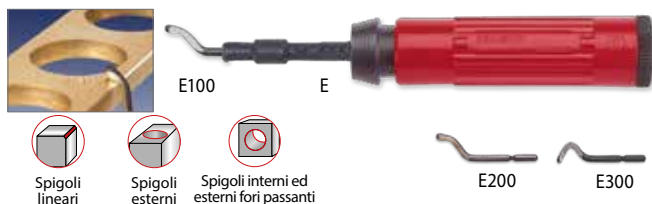

Set	Manico	Supporto	Lama	Codice nr.
Shaviv Set E	Manico Classico A	E	E100, E200, E300	155-29069

## SHAVIV Set B Alluminio\* Modello base

Il set più popolare per la sbavatura di fori, scanalature e spigoli. Monta tutte le lame di tipo B. Le lame possono essere inserite sia in senso longitudinale che perpendicolare.

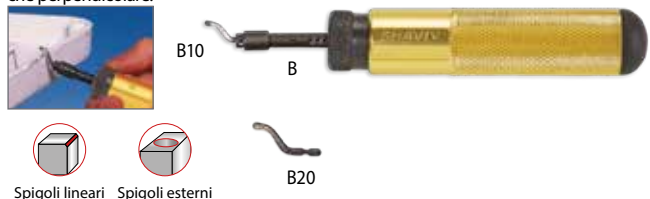

Set	Manico	Supporto	Lama	Codice nr.
Shaviv Set B in Alluminio	Alluminio	B	B10, B20	155-29066

## SHAVIV Set E in Alluminio\* Per applicazioni gravose

Per impieghi gravosi su fori, chiavette e spigoli. Porta tutte le lame di tipo E.

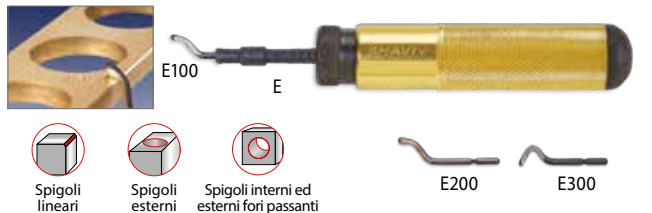

Set	Manico	Supporto	Lama	Codice nr.
Shaviv Set E in Alluminio	Alluminio	E	E100, E200, E300	155-00019

## Set C\* Per Applicazioni Gravose

Manico universale. Accetta tutte le lame e tutti i supporti. Per conservare le lame nel manico svitare semplicemente il cappuccio posteriore.

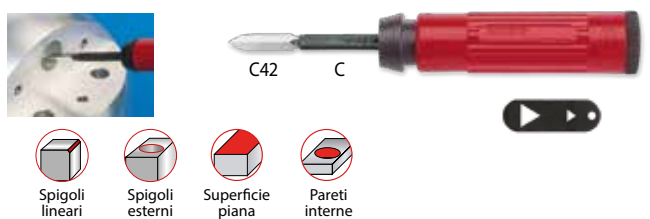

Set	Manico	Supporto	Lama	Codice nr.
Shaviv Set C	Manico Classico A	C	C42	155-29067

## Set HC\* HandyChuck

Estremamente versatile in finitura e raschiatura. Può portare piccole punte, maschi, alesatori, lime ed altri oggetti di diametro variabile tra 1 e 8 mm. Utile per riparare o montare orologi, apparecchiature elettroniche ed elettriche in miniatura.



Set	Manico	Lama	Codice nr.
Shaviv Set HC5	Manico universale HC1	C50	155-00163
Shaviv Set HC6	Manico universale HC1	C60	155-00164

## Set 1\* Sbavatura degli spigoli

Lo sbavatore originale per applicazioni gravose su angoli e spigoli. Il supporto non telescopico tiene la lama molto vicino al manico.



Set	Manico	Lama	Codice nr.
Shaviv Set 1	Manico 1	E100, E200, E300	155-29078

## Lama girevole



# Soluzioni economiche di sbavatura - Set Glo-Burr



## La serie Arcobaleno

### GLO-BURR B/E Kit da 48 pz.

Sbavatore maneggevole con lame intercambiabili.

Manico resistente ma leggero con una pratica clip da taschino.  
Per la sbavatura di acciaio, alluminio, rame e plastica.



Spigoli lineari



Spigoli esterni



Glo-Burr	Codice nr.
Kit Glo-Burr B - 48 pz.	154-29136
Kit Glo-Burr E - 48 pz.	154-00013

## Come sostituire le lame B + E dal Glo-Burr



1 Girare il manico fino alla posizione di allineamento (sbloccato).

2 Estrarre le lame da sostituire.

3 Inserire le nuove lame intercambiabili.

4 Girare il manico fino alla posizione di allineamento.

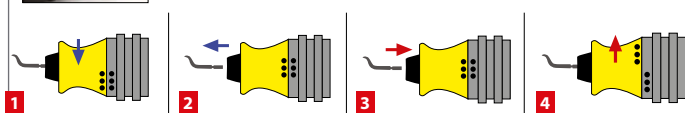

1

2

3

4

## Spare Blades Storage

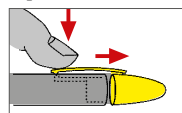

1. Premere verso il basso il tappo fino ad estrazione totale.

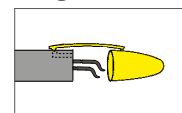

2. Inserire le lame intercambiabili all'interno del manico.

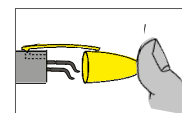

3. Richiudere il tappo fino a chiusura totale.

## Glo-Burr B - Operazioni di sbavatura standard

**B10 Glo-Burr Verde \*** | 155-29152  
Rimuovono bave con truciolo a spirale



**B20 Glo-Burr** | 155-00274  
Rotazione oraria ed antioraria per materiali a truciolo polveroso



**B30 Glo-Burr** | 155-00275  
Rimuovono bave interne ed esterne nei fori fino a 4 mm di spessore



**B11 Glo-Burr** | 155-00273  
Extra sottile. Rimuove bave da fori con micro diametri di 2 mm



\* **Glo-Burr B10** Il modello B10 può essere fornito nei seguenti colori:

Colore	Blu	Giallo	Rosso
Codice nr.	155-29134	155-29154	155-29153



Spigoli lineari



Spigoli esterni

## Glo-Burr E - Operazioni di sbavatura gravose

**E100 Glo-Burr Verde \*** | 155-29155  
Rimuovono bave con truciolo a spirale



**E200 Glo-Burr** | 155-00268  
Rotazione oraria ed antioraria per materiali a truciolo polveroso



**E300 Glo-Burr** | 155-00267  
Rimuovono bave interne ed esterne nei fori fino a 6 mm di spessore



**E111 Glo-Burr** | 155-00270  
Extra sottile. Rimuove bave da fori con micro diametri di 1.5 mm



\* **Glo-Burr E100** Il modello E100 può essere fornito nei seguenti colori:

Colore	Blu	Giallo	Rosso
Codice nr.	155-29133	155-29157	155-29156



Spigoli lineari



Spigoli esterni

## Glo-Burr Handy Kit

### Glo-Burr Handy Kit 4B

**Una composizione per ogni tipo di sbavatura**

Comprende 4 manici Glo-Burr B e lame B10, B20, B30, B11



### Glo-Burr Handy Kit 4E

**Una composizione per ogni tipo di sbavatura**

Comprende 4 manici Glo-Burr E e lame E100, E200, E300, E111



Set	Manico	Lama	Codice nr.
Handy Kit 4B	Glo-Burr	B10, B20, B30, B11	154-90042

Set	Manico	Lama	Codice nr.
Handy Kit 4E	Glo-Burr	E100, E200, E300, E111	154-29144

# Raschiatori ed altri utensili compatti

## Scrape-Burr 42 Raschiatore per applicazioni gravose



Questo raschiatore è provvisto di una lama fissa triangolare con tre spigoli taglienti per la finitura e la raschiatura di qualità.



Spigoli lineari Spigoli esterni Superficie piana Pareti interne



C42

Set	Manico	Lama	Codice nr.
Scrape-Burr 42	Glo-Burr	C42	155-90079

## Scrape-Burr 40 Raschiatore universale



Questo raschiatore è provvisto di una lama fissa triangolare con tre spigoli taglienti per la finitura e la raschiatura di qualità.



Spigoli lineari Superficie piana Pareti interne



C40

Set	Manico	Lama	Codice nr.
Scrape-Burr 40	Glo-Burr	C40	155-90078

## Scrape-Burr 400 Raschiatore per finitura



Questo mini utensile garantisce un'ottima finitura su pezzi di precisione. E' composto da una lama triangolare a tre taglienti, extra-sottile e resistente per raschiature e finiture di alta qualità.



Spigoli lineari Superficie piana Pareti interne



E400

Set	Manico	Lama	Codice nr.
Scrape-Burr E400	Glo-Burr	E400	155-90080

## Scrape-Burr Kit 3+1



**I tre raschiatori in un unico kit!**

In più, un manico Glo-Burr con lama B 10 **GRATIS**.



Spigoli lineari Spigoli esterni Superficie piana Pareti interne



C42



C40



E400



B10

Set	Manico	Lama	Codice nr.
Scrape-Burr Kit	Glo-Burr	B10, C40, C42, E400	154-90081

## UNIBURR sbasatori universali

### UB2 DisposaBurr

Fornito con lama B 10 non intercambiabile.



Spigoli lineari Spigoli esterni



Codice nr.: 155-29190

Sbavatore maneggevole con pratica clip da taschino.

Per la sbavatura di acciaio, alluminio, rame e plastica. Disponibile in vari colori.

UNIBURR	Nero	Blu	Verde	Rosso
UB2	155-00168	155-29187	155-00169	155-29081

### UB2000

Fornito con lama B 10 intercambiabile, che può essere inserita sia assialmente sia perpendicolarmente al manico.



Spigoli lineari Spigoli esterni



Codice nr.: 155-29192

Sbavatore maneggevole con pratica clip da taschino.

Per la sbavatura di acciaio, alluminio, rame e plastica. Disponibile in vari colori.

UNIBURR	Nero	Blu	Verde	Rosso
UB2000	155-29202	155-29107	155-29203	155-29191

## NOVITA'! Manici con alluminio anodizzato

### UB1 DisposaBurr

Fornito con lama E 100 non intercambiabile.



Spigoli lineari Spigoli esterni



Codice nr.: 155-29080

Sbavatore maneggevole con pratica clip da taschino.

Per la sbavatura di acciaio, alluminio, rame e plastica. Disponibile in vari colori.

UNIBURR	Nero	Blu	Verde	Rosso
UB1	155-00165	155-29181	155-00166	155-29184

### MB2000

Manico esagonale resistente per applicazioni gravose. E' fornito con lama intercambiabile E 100.

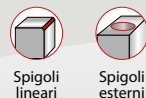

Spigoli lineari Spigoli esterni



Codice nr.: 155-29161

Sbavatore maneggevole con pratica clip da taschino.

Per la sbavatura di acciaio, alluminio, rame e plastica. Disponibile in vari colori.

UNIBURR	Nero	Blu	Verde	Rosso
MB2000	155-29158	155-29092	155-29159	155-29160



# Utensili con lama in ceramica e pulitori di tubi



## Cera-Burr Utensile con lama in ceramica



Utensili in ceramica per la sbavatura di plastica e materiali teneri. La nuova lama raggiata permette di raggiungere posizioni angolate. La lama in ceramica di alta qualità è provvista di manico robusto ma leggero. E' l'utensile ideale per rimuovere i segni dell'espulsore su parti in plastica. Permette di evitare gli incidenti tipici dell'utilizzo delle lamette del cutter.



Set	Manico	Lama	Codice nr.
Cera-Burr	Glo-Burr	Fissa	155-90084
Cera-Burr Curve Q11	Glo-Burr	Fissa	155-00239

## CERAMIX Set Q10

Manico per applicazioni gravose con lama in ceramica Q10  
Per migliori risultati e per prevenire graffi regolare l'angolo tra lama e il materiale. Lama rovesciabile per due tipi di impiego.

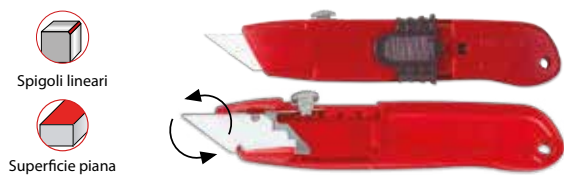

Lama rovesciabile per due tipi di impiego:

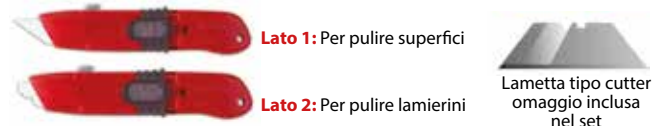

Set	Manico	Lama	Codice nr.
Set Ceramix Q10	Manico Ceramix	Q10	155-29238

## CERAMIX Set raggiato Q12

Manico per applicazioni gravose con lama in ceramica Q11  
Per migliori risultati e per prevenire graffi regolare l'angolo tra la lama ed il materiale. Lama rovesciabile per due tipi di impiego.



Lama rovesciabile per due tipi di impiego:

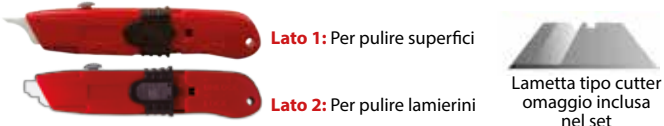

Set	Manico	Lama	Codice nr.
Set Ceramix Q12	Manico Ceramix	Q11	155-00238

## Plum-Burr Pulitore di tubi per impieghi gravosi e standard

Per sbavare tubi sia sullo spigolo interno sia su quello esterno. Ideale per idraulici, installatori ed elettricisti.

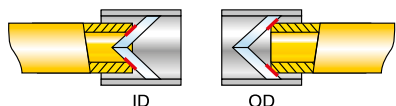

- Adatto per tubi di alluminio, rame e ottone
- Plum-Burr Metal - Per tubi di diametro compreso tra 6 e 41 mm
- Plum-Burr Plastic - Per tubi di diametro compreso tra 4,8 e 38 mm

Set	Codice nr.
Plum-Burr Metallo	155-90082
Plum-Burr Plastica	155-90083

## Lame CERAMIX

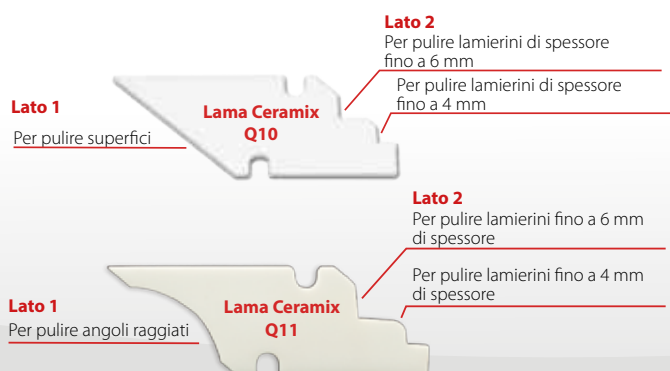

Descrizione delle lame	Lama	Codice nr.
Lama Ceramix Q10	Q10	151-29236
Lama raggiata Ceramix Q11	Q11	151-00132

# Kit Multipiepo

## Top 3 Mango II Starter Kit

Il kit per tutto ciò che occorre in officina. Comprende il manico Mango II con le tre tipologie di lame e di supporti più popolari per i differenti tipi di sbavatura.

Contiene:

- \* Manico Mango II
- \* Supporti - B, C, & E
- \* Lame - B10, B20, B30, B50, B60, C40, E100, & E300



**Top 3 Mango II Starter Kit** Codice nr.: 154-90085



## Kit Classico KPC2 I 5 favoriti

I set più diffusi in un unico kit.

Contiene:

- \* Set B: per la sbavatura in rotazione
  - \* Set C: per lavori di raschiatura
  - \* Set D: per la sbavatura di lamierini
  - \* Set E: per la sbavatura gravosa in rotazione
  - \* Set F: per la svasatura e la sbavatura di fori
- N.B. Ogni set è fornito con il manico classico A.



**Kit Classico KPC2** Codice nr.: 154-29060



## Kit TD Kit per stampisti

Utensili in miniatura per la finitura di precisione degli stampi. Il kit è fornito in un elegante astuccio di cuoio.

Contiene:

- \* UF1 - Lama piatta diamantata
- \* US1 - Raschietto triangolare
- \* US2 - Raschietto piatto
- \* US3 - Raschietto tondo
- \* US4 - Raschietto con spigolo
- \* UB38 - Microsbavatore per fori diametro 2 mm



UF1	Codice nr.: 155-00051
US1	Codice nr.: 155-00156
US2	Codice nr.: 155-00173
US3	Codice nr.: 155-00174
US4	Codice nr.: 155-00175
UB38	Codice nr.: 155-29084
Kit TD	Codice nr.: 154-29079



## Kit U Finitura ultrafine

Per lavori di grande precisione.

Contiene:

- \* Manico in alluminio
- \* Supporto U fisso
- \* Supporto B rotante
- \* 4 lame di tipo B per la sbavatura in rotazione - B10, B11, B20 & B30
- \* 4 raschietti intercambiabili di tipo U - BUS1, BUS2, BUS31 & BUS4
- \* Punta a tracciare E500C



**Kit U** Codice nr.: 154-29228



## Kit KWC Classico

Il kit universale con contenitore in plastica o in legno

Kit universale offre tutto ciò che occorre per 1000 e + impieghi.

Contiene:

- \* Manico Classico A
- \* Supporti - B, C, D, E & F
- \* Lame - B10, B20, B30, B50, B60, B70, C40, C42, D80C, E100, E200, E300, E350, E600 & F20



**KWC Classico in plastica** Codice nr.: 154-00008

**Mango II Kit KWC** Codice nr.: 154-00024



## Kit KPA Mango II Per la sbavatura della plastica

Il kit perfetto per la sbavatura della plastica.

Contiene:

- \* Manico Mango II
  - \* Sbvatore UB38
  - \* Supporti - B, E, G3 & LP
  - \* Lame - B12, B25, E110, E700, G30C & L10
- N.B. fornibile anche con il manico classico A.



**Kit Mango II KPA** Codice nr.: 154-00037

**Kit Classico KPA** Codice nr.: 154-00012



## TD kit intercambiabile

Lame intercambiabili oggi disponibili per Shaviv linea professionale dedicata alle microsbavature e raschiatura per l'industria degli stampi

Contiene:

- \* Manico Alluminio
- \* lama raschiatore: BUS1 - raschiatore triangolare, BUS2 - raschiatore piatto, BUS3 - raschiatore arrotondato
- \* BUS4 - raschiatore ad uncino per angoli
- \* Shaviv UF1 Mini File - rivestito al diamante
- \* raschiatore serie BURR 400 per finitura extra fine
- \* supporto U fisso



**TD Interchangeable Kit** Codice nr.: 154-00046

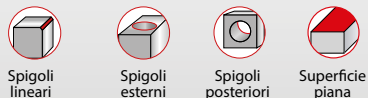

## Kit universale per lamierini

Perfetto per una grande varietà di applicazioni ed anche per la sbavatura di lamierini nei materiali più diversi, metalli, materie plastiche, materiali acrilici. Elimina gli angoli frastagliati un lato per volta ovvero contemporaneamente su entrambi i lati

Contiene:

- \* Manico Mango II
- \* Sbvatore - B, BR, D, D5 & E
- \* Lame - B10, B20, B30, B70, E100, E200, E300, D80C, D82C, D85, 2 x R10 & 2 x R30
- \* Salvamano



**Kit universale per lamierini** Codice nr.: 154-00038



# Indice delle lame

Lama	Codice nr.	Descrizione	Lama (in figura la direzione della lavorazione)	Applicazioni										Materiale											
				Spigoli lineari	Spigoli esterni	Spigoli tondi	Spigoli interni ed esterni fori passanti	Spigoli posteriori	Pareti interne	Superficie piana	Lamierini	Chivette	Angoli retti	Acciaio	Alluminio	Rame	Ottone	Ghisa	Acciai inossidabili	Acciai duri	Plastiche	Metallo duro e vetro	Legno		
B1	151-29215	Lama al cobalto di lunga durata. Geometria N1.		●	●										●	●	●			●	●				
B10	151-29212	HSS. Sbava materiali a truciolo lungo.	★	●	●										●	●	●				●	●			
B10C	151-29013	Metallo duro integrale, geometria B10.		●	●										●	●	●				●	●			
B10D	151-29014	Diamantata. Geometria B10.		●	●																		●		
B10L	151-29095	B10 per mancini.		●	●										●	●	●					●	●		
B10P	151-29015	Rivestita TiN , alta resistenza all'usura. Geometria B10.		●	●										●	●	●				●	●			
B10PL	151-29096	B10 rivestita TiN. Per mancini.		●	●										●	●	●				●	●			
B10S	151-29210	Al cobalto. Geometria B10.		●	●										●	●	●				●	●			
B11	151-29108	Extrasottile, HSS. Sbava fori con Ø min. 2mm.		●	●										●	●	●					●	●		
B11P	151-00120	Rivestita TiN, alta resistenza all'usura. Geometria B11.		●	●										●	●	●				●	●			
B12	151-29016	Tipo corto, HSS.	★	●	●										●	●	●					●	●		
B12P	151-19017	Tipo corto, rivestita TiN, alta resistenza all'usura.		●	●										●	●	●				●	●			
B20	151-19019	HSS. Doppio senso di rotazione.	★	●	●												●	●			●	●		●	
B20C	151-19020	Metallo duro integrale. Doppio senso di rotazione.		●	●												●	●	●		●	●		●	
B20P	151-29021	Rivestita TiN, alta resistenza all'usura, Doppio senso di rotazione.		●	●												●	●	●		●	●		●	
B25	151-29022	Lama sottile particolarmente concepita per plastiche.		●	●										●	●	●					●	●		
B25C	151-29110	Metallo duro integrale, lama sottile particolarmente concepita per plastiche dure.		●	●										●	●	●					●	●		
B30	151-29023	Sbava contemporaneamente gli spigoli interni ed esterni dei fori sino a 4 mm. di spessore.	★				●								●	●	●					●	●		
B30P	151-29024	Rivestita TiN, alta resistenza all'usura. Geometria B30.					●								●	●	●					●	●		
B32	151-29025	Doppio senso di rotazione. Geometria B30.					●										●	●			●	●		●	
B50C	151-29026	Punta a tracciare. Può essere riaffilata.								●					●	●	●	●	●	●	●	●	●	●	●
B60	151-29027	HSS. Adatta per la parte interna dei fori sino a 20 mm. di spessore.					●								●	●	●					●	●		
B70	151-29028	Con placchetta in metallo duro. Sbava lamierini sino a 3,5 mm. di spessore.								●					●	●	●	●	●	●	●	●	●	●	●
C40	151-29029	Piccola, 4 mm., raschietto triangolare in HSS per lavori di precisione.	★					●	●	●					●	●	●	●	●	●	●	●	●	●	●
C42	151-29030	Standard, 8 mm., raschietto triangolare in HSS.	★					●	●	●					●	●	●	●	●	●	●	●	●	●	●
C50	151-29117	Doppia, 7,8 mm., raschietto triangolare.	★					●	●	●					●	●	●	●	●	●	●	●	●	●	●
C60	151-29118	Doppia, 4,8 mm., raschietto triangolare.						●	●	●					●	●	●	●	●	●	●	●	●	●	●
D80C	151-29031	Metallo duro integrale, 6 taglienti. Per sbavare lamierini sino a 3 mm. di spessore.	★							●	●				●	●	●	●	●	●	●	●	●	●	●
D82C	151-29032	Per applicazioni gravose. Lama doppia in metallo duro. Per sbavare lamierini sino a 9 mm. di spessore.								●	●				●	●	●	●	●	●	●	●	●	●	●
D85	151-29033	HSS con rompitruciolo e 6 taglienti. Per sbavare lamierini sino a 6 mm. di spessore.								●	●				●	●	●	●	●	●	●	●	●	●	●

Lama	Codice nr.	Descrizione	Lama (in figura la direzione della lavorazione)	Applicazioni										Materiale								
				Spigoli lineari	Spigoli esterni	Spigoli tondi	Spigoli interni ed esterni fori passanti	Spigoli posteriori	Pareti interne	Superficie piana	Lamierini	Chiavette	Angoli retti	Acciaio	Alluminio	Rame	Ottone	GHISA	Acciai inossidabili	Acciai duri	Plastiche	Metallo duro e vetro
E100	151-29034	HSS. Per applicazioni gravose. Sbava materiali a truciolo lungo.		●	●									●	●	●				●		
E100C	151-29035	Metallo duro integrale, resistente all'usura. Geometria E100.		●	●													●	●			
E100D	151-29036	Diamantata. Geometria E100.		●	●																●	
E100L	151-29098	E100 per mancini.		●	●									●	●	●				●		
E100P	151-29037	Rivestita TiN, alta resistenza all'usura. Geometria E100.		●	●									●	●			●	●			
E100PL	151-00022	Rivestita TiN per mancini.		●	●									●	●			●	●			
E100S	151-29211	A lunga durata al cobalto. Geometria E100.		●	●									●	●	●			●	●		
E110	151-29038	gambo E, lama come B10 per materiali a truciolo lungo. Sbava fori a partire da un Ø min. di 2 mm.		●	●									●	●	●			●	●		
E110P	151-29039	Rivestita TiN, alta resistenza all'usura. Geometria E110.		●	●									●	●			●	●			
E111	151-29109	Sottile in HSS. Sbava fori a partire da un Ø min. di 1,5 mm.		●	●									●	●	●			●	●		
E111P	151-00099	Rivestita TiN, alta resistenza all'usura. Geometria E111.		●	●									●	●	●			●	●		
E120	151-29058	Gambo E tagliente come B20 per materiali a truciolo corto. Doppio senso di rotazione		●	●											●	●			●	●	
E200	151-29040	HSS per materiali a truciolo corto. Doppio senso di rotazione		●	●											●	●			●	●	●
E200P	151-29099	Rivestita TiN, alta resistenza all'usura. Geometria E200.		●	●											●	●			●	●	●
E200S	151-00107	Al cobalto. Geometria E200.		●	●											●	●			●	●	●
E200C	151-29041	Metallo duro integrale, resistente all'usura. Geometria E200.		●	●											●	●		●	●		●
E250	151-29106	Specialmente concepita per la plastica. Molto sottile per applicazioni gravose.		●	●										●	●	●			●	●	
E300	151-29042	HSS per materiali a truciolo lungo. Per sbavatura simultanea dello spigolo interno ed esterno dei fori sino a 6 mm. di spessore.		●			●							●	●	●						
E300P	151-29227	Rivestita TiN, alta resistenza all'usura. Geometria E300.		●			●							●	●	●			●	●		
E320	151-29043	HSS per materiali a truciolo corto. Per sbavatura simultanea dello spigolo interno ed esterno dei fori sino a 6 mm. di spessore. Doppio senso di rotazione.					●									●	●			●	●	●
E350	151-29044	HSS per materiali a truciolo corto. Doppio senso di rotazione.		●	●											●	●			●	●	
E400	151-29233	Miniraschietto triangolare.		●					●	●				●	●	●	●	●	●	●	●	●
E450	151-29234	Quattro lame in una.		●							●			●	●	●	●	●	●	●	●	●
E500C	151-29111	Punta a tracciare in metallo duro. Può essere riaffilata.									●			●	●	●	●	●	●	●	●	●
E600	151-29045	HSS. Sbava punti di difficile accesso in fori sino a 20 mm. di spessore.		●					●					●	●	●				●	●	
E601	151-29046	Extralunga in HSS. Sbava punti di difficile accesso in fori sino a 40 mm. di spessore.							●					●	●	●				●	●	
E604	151-29231	Sbava fori passanti e punti di difficile accesso. Naso corto							●					●	●	●				●	●	
E700	151-29047	HSS per materiali a truciolo lungo. Eccellente applicazione per la sbavatura di pareti tonde interne e fori passanti.								●				●	●	●				●	●	
E707	151-29232	Sbavatura di profili.		●										●	●	●	●	●	●	●	●	●
E720	151-29048	HSS per materiali a truciolo corto. Eccellente applicazione per la sbavatura di pareti tonde interne e fori passanti. Doppio senso di rotazione.								●						●	●			●	●	●
E750	151-29113	HSS. Particolarmente concepita per la sbavatura di gomma e plastiche morbide.		●	●															●	●	
E755	151-29085	HSS. Per sbavare angoli retti con altezza pari a 1 mm.		●								●		●	●	●	●	●	●	●	●	●
E800	151-29018	HSS per materiali a truciolo lungo. Sbava angoli retti di poca profondità.		●	●									●	●	●			●	●		
E10	151-29216	Lama al cobalto di lunga durata per materiali a truciolo lungo. Ideale per applicazioni gravose.		●	●									●	●	●			●	●		
ES10	151-29105	HSS durable blade. S10 geometry.		●	●									●	●	●				●	●	



# Indice delle lame

Lama	Codice nr.	Descrizione	Lama (in figura la direzione della lavorazione)	Applicazioni											Materiale									
				Spigoli lineari	Spigoli esterni	Spigoli tondi	Spigoli interni ed esterni fori passanti	Spigoli posteriori	Pareti interne	Superficie piana	Lamierini	Chiavette	Angoli retti	Acciaio	Alluminio	Rame	Ottone	Chiusa	Acciai inossidabili	Acciai duri	Plastiche	Metallo duro e vetro	Legno	
F12	151-29049	Sbavatore per spigoli esterni di fori sino a 12 mm. di diametro.			●														●	●	●			
F20	151-29050	Sbavatore per spigoli esterni di fori sino a 20 mm. di diametro.	★		●														●	●	●			
F30	151-29051	Sbavatore per spigoli esterni di fori sino a 30 mm. di diametro.			●														●	●	●			
F26X	151-29147	Eccellente applicazione per la sbavatura esterna di tubi, cilindri e similari sino a 26 mm. di diametro.	★			●													●	●	●			
G10	151-29052	HSS. Sbavatura di chiavette sino a 15 mm. di larghezza.	★											●					●	●	●			
G20	151-29053	HSS, 4 spigoli taglienti. Per chiavette sino a 10 mm. di larghezza.												●					●	●	●			
G30C	151-29115	Metallo duro integrale, 3 spigoli taglienti. Sbava angoli scanalati e elimina raggature indesiderate.												●					●	●	●			
G40C	151-29103	Metallo duro integrale, 4 spigoli taglienti. Per chiavette sino a 10 mm. di larghezza.												●					●	●	●			
L10	151-29063	HSS, 4 spigoli taglienti. Sbava spigoli esterni sino a un diametro di 20 mm. e oltre. Il lato "A" sbava materiali a truciolo lungo; il lato "B" sbava materiali a truciolo corto.			●	●									A	A	A	B	B	A		A	B	●
R10	151-29141	Lama doppia tonda in HSS. Il lato "A" sbava materiali a truciolo lungo; il lato "B" sbava materiali a truciolo corto.	★		●										A	A	A	B	B	A		A	B	●
R20	151-29142	Lama doppia tonda in HSS per applicazioni gravose in materiali a truciolo lungo.	★		●										●	●	●			●		●		
R30	151-29143	Produce sagome arcuate in materiali sino a 16 mm. di spessore. Utilizzare una lama singola R30 per uno spigolo dritto oppure due lame per sbavare simultaneamente entrambi gli spigoli.			●										●				●		●			
BUS1	151-29195	Raschietto triangolare per superfinitura.													●	●			●	●	●			●
BUS2	151-29196	Raschietto piatto per superfinitura.													●	●			●	●	●			●
BUS31	151-29197	Raschietto rotondo per superfinitura.													●	●			●	●	●			●
BUS4	151-29198	Raschietto con spigolo per superfinitura.													●	●			●	●	●			●
Q10	151-29236	Lama doppia in ceramica.			●																			●
Q11	151-00132	Double-sided deburring. Curved ceramic blade for curved edges and small ridges.			●																			●
Finishing Bit	156-00001	Bit esagonale da D1/4" con lama (4 pz.).			●	●																		●

## La scelta per gli usi industriali

Le lame, i set, i kit e gli utensili SHAVIV vengono utilizzati dalle aziende leader nel settore degli stampi, automotive, aviazione, materie plastiche, elettronica ed altro.



Stampi



Elettronica



Materie plastiche



Automotive



Lavorazione dei metalli



Idraulica



Aviazione

## Due convenienti set con lame rivestite TiN per una maggior durata

### Multi proposta serie lame B in set

Per sbavatura standard

- 5 coppie di lame serie B rivestite TiN:  
B10Px2, B11P x 2, B12P x 2, B20P x 2, B30P x 2

### Multi proposta serie lame E in set

Per sbavatura gravosa

- 5 coppie di lame serie E rivestite TiN:  
E100Px2, E110P x 2, E111P x 2, E200P x 2, E300P x 2



Multi proposta serie lame B in set  
Codice nr.: 155-00252



Multi proposta serie lame E in set  
Codice nr.: 155-00251



# Supporti

Supporto E Porta tutte le lame di tipo E.	 Codice nr.: 153-29004
Supporto B Porta tutte le lame di tipo B. Usare assialmente o perpendicolarmente.	 Codice nr.: 153-29000
Supporto M Porta tutte le lame sia di tipo B sia di tipo E.	 Codice nr.: 153-29138
Supporto C Porta le lame C40 & C42.	 Codice nr.: 153-29001
Supporto D Porta le lame D80C & D82C.	 Codice nr.: 153-29002
Supporto D5 Porta la lama D85.	 Codice nr.: 153-29003
Supporto F Porta tutte le lame di tipo F.	 Codice nr.: 153-29005
Supporto BURR-BR.	 Codice nr.: 153-29139

Supporto FR Con arponismo di non ritorno porta tutte le lame di tipo F.	 Codice nr.: 153-29006
Supporto U Porta tutte le lame di tipo BUS.	 Codice nr.: 153-29121
Supporto L Porta la lama L10.	 Codice nr.: 153-29010
Supporto G Porta le lame G10, G20 & G40C.	 Codice nr.: 153-29007
Supporto G4 Angolato per rendere facile l'accesso all'area di lavoro. Porta le lame G10, G20 & G40C.	 Codice nr.: 153-29102
Supporto G3 Angolato per rendere facile l'accesso all'area di lavoro. Porta le lame G30C.	 Codice nr.: 153-29094
Salvamano Salvamano in acciaio inossidabile per proteggere la mano.	 Codice nr.: 152-00030

## Applicazioni e guida alla scelta degli utensili



**Spigoli lineari**  
Per i set: B, C, E, HC, M, 1, Burr-Bi

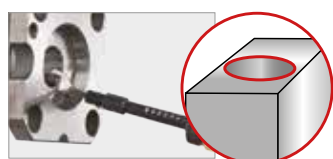

**Spigoli esterni**  
Per i set: B, C, E, F, FR, HC, M, U, 1

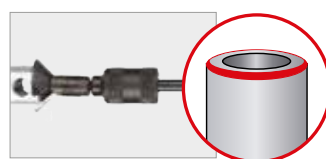

**Spigoli tondi**  
Per i set: Burr-Ex, L

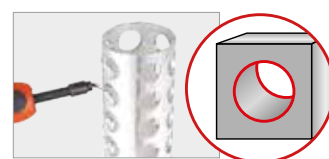

**Spigoli interni ed esterni fori passanti**  
Per i set: E, M, 1



**Spigoli posteriori**  
Per i set: C, E, HC, U



**Pareti interne**  
Per i set: C, HC, U



**Superfici piane**  
Per i set: C, D, HC, U



**Lamierini**  
Per i set: D, Burr-Bi



**Spigolo interno Plum-Burr**



**Chiavette**  
Per i set: G, U



**Angoli retti**  
Per i set: G3



**Testimone di iniezione Cera-Burr**

# Riferimento pagina

Codice nr.	Pag.	Codice nr.	Pag.	Codice nr.	Pag.	Codice nr.	Pag.	Codice nr.	Pag.
151-00022	15	151-29053	16	153-29003	17	155-00174	13	155-29154	10
151-00099	15	151-29058	15	153-29004	17	155-00175	13	155-29155	10
151-00107	15	151-29063	16	153-29005	17	155-00177	5	155-29156	10
151-00120	14	151-29085	15	153-29006	17	155-00178	5	155-29157	10
151-00129	7	151-29095	14	153-29007	17	155-00179	5	155-29158	11
151-00130	7	151-29096	14	153-29010	17	155-00180	5	155-29159	11
151-00132	12, 16	151-29098	15	153-29094	17	155-00181	5	155-29160	11
151-00137	7	151-29099	15	153-29102	17	155-00182	5	155-29178	4
151-00138	7	151-29103	16	153-29121	17	155-00183	5	155-29180	11
151-00139	7	151-29105	15	153-29138	17	155-00184	5	155-29181	11
151-19017	14	151-29106	15	153-29139	17	155-00199	4	155-29184	11
151-19019	14	151-29108	14	154-00008	13	155-00206	4	155-29187	11
151-19020	14	151-29109	15	154-00012	13	155-00220	4	155-29190	11
151-29013	14	151-29110	14	154-00013	10	155-00221	4	155-29191	11
151-29014	14	151-29111	15	154-00024	13	155-00222	3	155-29192	11
151-29015	14	151-29113	15	154-00030	6	155-00223	3	155-29202	11
151-29016	14	151-29115	16	154-00031	7	155-00224	4	155-29203	11
151-29018	15	151-29117	14	154-00032	7	155-00231	6	155-29229	8
151-29021	14	151-29118	14	154-00033	6	155-00232	6	155-29238	12
151-29022	14	151-29141	16	154-00034	6	155-00238	12	155-90056	5
151-29023	14	151-29142	16	154-00035	6	155-00239	12	155-90058	5
151-29024	14	151-29143	16	154-00036	6	155-00251	16	155-90060	5
151-29025	14	151-29147	16	154-00037	13	155-00252	16	155-90061	5
151-29026	14	151-29195	16	154-00038	13	155-00258	7	155-90062	3
151-29027	14	151-29196	16	154-00040	6	155-00259	7	155-90064	3
151-29028	14	151-29197	16	154-00045	6	155-29057	2	155-90065	3
151-29029	14	151-29198	16	154-00046	13	155-29065	9	155-90066	5
151-29030	14	151-29207	14	154-29060	13	155-29066	9	155-90068	5
151-29031	14	151-29210	14	154-29079	13	155-29067	9	155-90071	3
151-29032	14	151-29211	15	154-29136	10	155-29068	3	155-90072	3
151-29033	14	151-29212	14	154-29144	10	155-29069	9	155-90073	4
151-29034	15	151-29215	14	154-29228	13	155-29070	3	155-90074	4
151-29035	15	151-29216	15	154-90042	10	155-29071	3	155-90076	8
151-29036	15	151-29227	15	154-90081	11	155-29072	4	155-90078	11
151-29037	15	151-29231	15	154-90085	13	155-29076	4	155-90079	11
151-29038	15	151-29232	15	155-00019	9	155-29078	9	155-90080	11
151-29039	15	151-29233	15	155-00051	13	155-29081	11	155-90082	12
151-29040	15	151-29234	15	155-00156	13	155-29084	13	155-90083	12
151-29041	15	151-29236	12, 16	155-00161	8	155-29092	11	155-90084	12
151-29042	15	152-00003	2	155-00162	5	155-29107	11	156-00001	8, 16
151-29043	15	152-00005	2	155-00163	9	155-29119	4	156-00003	7, 8
151-29044	15	152-00009	2, 5	155-00164	9	155-29133	10		
151-29045	15	152-00013	2, 8	155-00165	11	155-29134	10		
151-29046	15	152-00016	2,5	155-00166	11	155-29140	4		
151-29047	15	152-00019	2, 3	155-00168	11	155-29146	4		
151-29048	15	152-00026	2	155-00169	11	155-29152	10		
151-29049	16	152-00030	3, 17	155-00173	13	155-29153	10		
151-29050	16	153-29000	17						
151-29051	16	153-29001	17						
151-29052	16	153-29002	17						

Il tocco finale  
per la finitura

Your Profession  
Your Kit™

da SHAVIV

Soluzioni d'avanguardia per la sbavatura

# SERIE PROFESSIONALE

NOVITÀ

Soluzioni complete per la rimozione delle bave

SHAVIV – leader mondiale nelle soluzioni per la sbavatura, propone la propria esperienza ai professionisti e agli utilizzatori domestici. Adattiamo le nostre soluzioni al Vostro naturale ambiente di lavoro.

**Il tuo kit professionale include:**

- Kit per Eletttricisti (154-00060)
- Kit per idraulica (154-00064)
- Kit per lavorare Alluminio (154-00061)
- Kit per officine autoriparazioni (154-00062)
- Kit "fai da te" (154-00063)



✓ ACCURATO  
✓ SICURO  
✓ VELOCE

SOLUZIONI PERSONALIZZATE PER LA SBAVATURA DEDICATE AI PROFESSIONISTI E ALLE FORNITURE DOMESTICHE

NOVITÀ

## Multi Set E mango II

Un set completo  
per le applicazioni di  
sbavatura e raschiatura  
più popolari!

**E100** – Lama per applicazioni  
gravose con truciolo a spirale



**Supporto E** – Per tutte le  
lame tipo E



**Manico Mango II per accesso  
remoto** – Impugnatura ergonomica



**E200** – Sbava materiali a  
truciolo polveroso



**E300** – Sbavatura  
simultanea dello spigolo  
interno ed esterno



**E400 Scraper** – Extra-sottile,  
lama triangolare per raschiare  
precisa

**Applicazioni:** Spigoli lineari | Spigoli esterni | Spigoli interni ed esterni fori passanti | Spigoli posteriori | Pareti interne | Superfici piane

**Materiali:** Alluminio | Rame | Ottone | Ghisa | Acciaio Inox | Plastica | Legno

# SHAVIV **Novità** GENiUS™

## Sbavatori manuali Sempre più facili da usare!

### Introduzione del **primo selezionatore mondiale sulle applicazioni di sbavatura manuale**

Il nuovo software applicativo **SHAVIV GENiUS™** ti permette di navigare e selezionare la soluzione corretta di sbavatura manuale, basandosi sul materiale e il lavoro da svolgere.

Scegli il set di utensili SHAVIV più idoneo alla tua applicazione in pochi semplici passaggi con [www.shaviv-genius.com](http://www.shaviv-genius.com)



**SHAVIV**  
Soluzioni per la sbavatura

[www.sefmeccanotecnica.it](http://www.sefmeccanotecnica.it)

[www.sefmeccanotecnica.it](http://www.sefmeccanotecnica.it)



Sede  
Via degli Orefici  
Blocco 26 - Centergross  
40050 Funo · Bologna · Italia  
tel +39 051 66.48.811  
[vendite@sefmeccanotecnica.it](mailto:vendite@sefmeccanotecnica.it)  
[sefmeccanotecnica.it](http://sefmeccanotecnica.it)

Per informazioni tecniche:

Marco Montesano  
responsabile tecnico nord-ovest  
+39 347 076 7604

Mattia Boni  
responsabile tecnico Emilia Romagna  
+39 331 277 3481

Luca Peretti  
direttore tecnico  
+39 335 231 858

